



ELECTRONIC KIT'S MANUAL

INSTALLATION

**THE ELECTRONIC KIT MUST BE INSTALLED BY A
PROFESSIONAL
(PWC DEALER OR FLYBOARD® DISTRIBUTOR)**

PHASE 1-1: SET THE HOUSING ON THE BATTERY



INSTRUCTIONS:

SET THE BRACKET ITEM.125 UNDER THE BATTERY'S STRAPS

PHASE 1-2: FIXING THE ELECTRONIC CASE

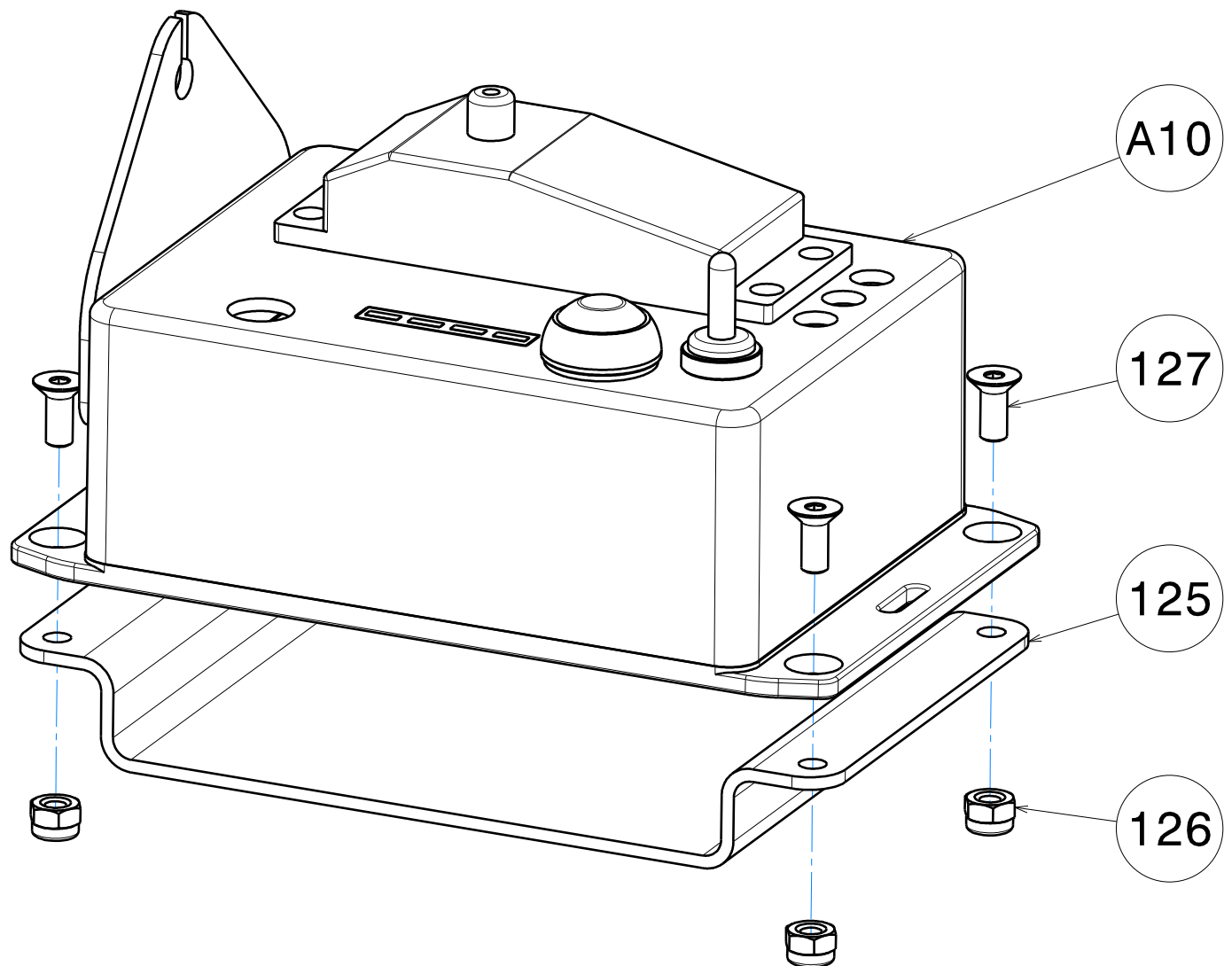

INSTRUCTIONS:

SET THE CASE ON THE BRACKET ITEM.125 WITH THE NUTS ITEM.126 AND THE SCREW ITEM.127

PHASE 1-3: BATTERY'S CONNECTION

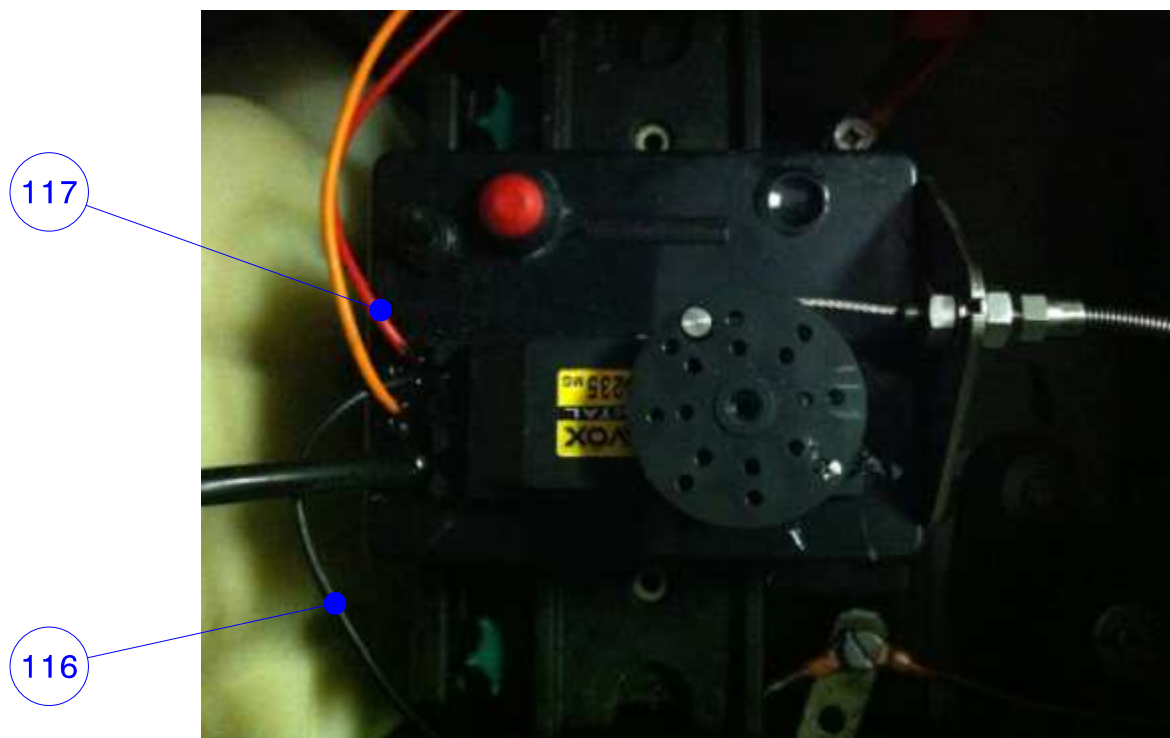

INSTRUCTIONS:

1. CONNECT THE RING EYELET RED WIRE TO + BATTERY
2. CONNECT THE RING EYELET BLACK WIRE TO - BATTERY

PHASE 2-1: THROTTLE CABLE

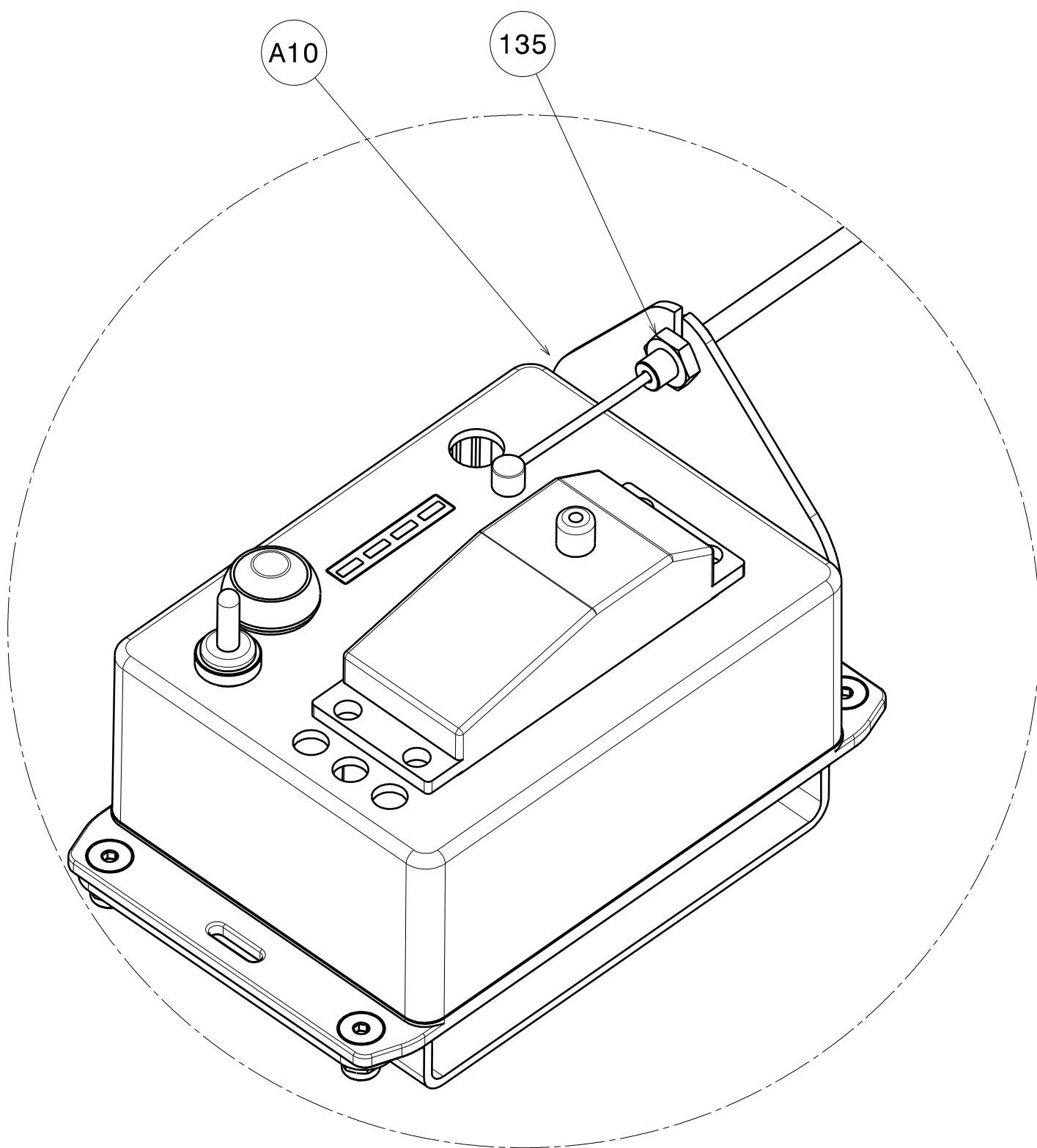

INSTRUCTIONS:

SET THE CABLE ITEM.135 ON THE PLATE OF THE CASE ITEM.A10

SET THE THROTTLE CABLE REFERRING TO THE APPROPRIATE ASSEMBLY SHEET

PHASE 2-2: SET THE THROTTLE CABLE

135



INSTRUCTIONS: SEAD00

ALL MODELS EXCEPT THOSE WITH THE ELECTRIC THROTTLE

SET THE THROTTLE OF THE FLYBOARD IN PARALLEL WITH THE THROTTLE OF THE PWC

PHASE 2-2: SET THE THROTTLE CABLE

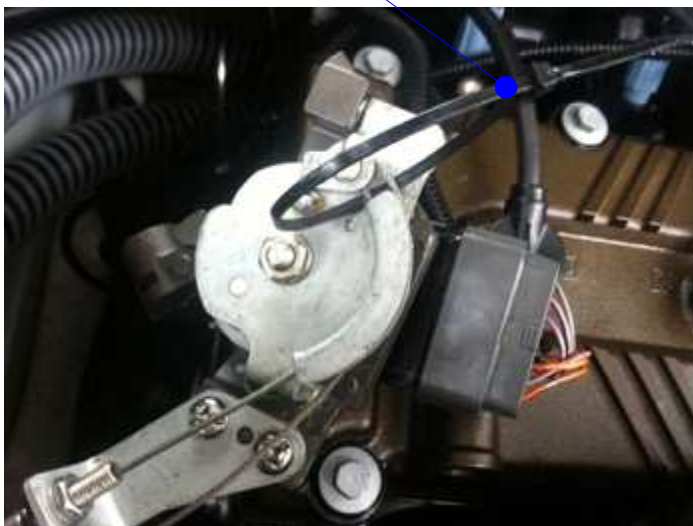
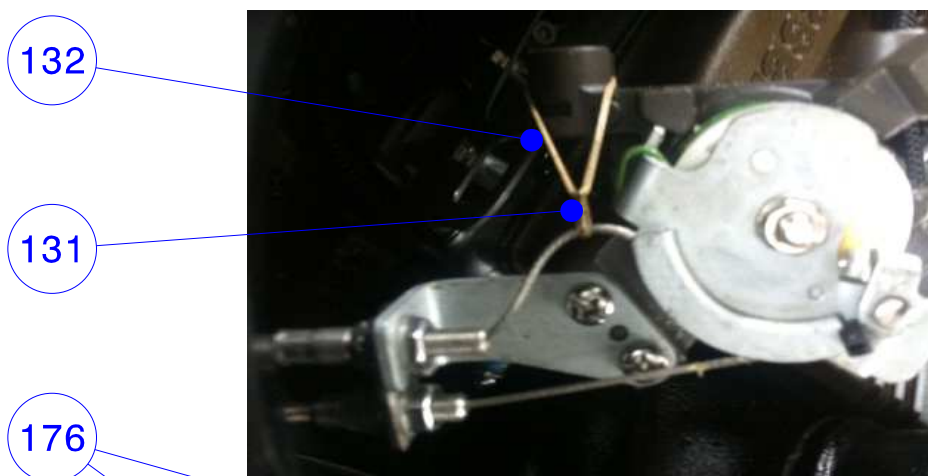
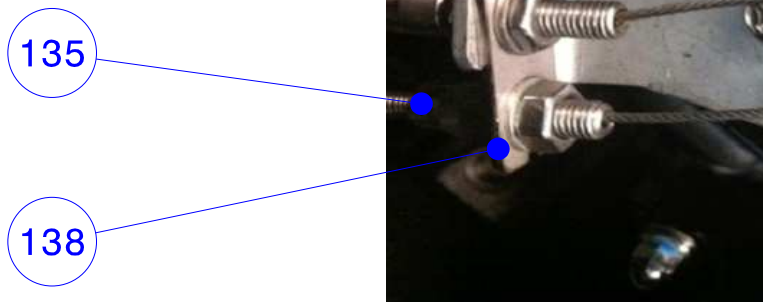

INSTRUCTIONS: KAWASAKI 300

1. SET THE THROTTLE OF THE FLYBOARD IN PARALLEL WITH THE THROTTLE OF THE PWC USING THE PART ITEM.138
2. PUT THE ELASTIC ITEM.131 AS IN THE PICTURE
3. INSERT A HOSE CLAMP TO ATTACH THE TWO WIRES TOGETHER AS SHOWN IN THE PICTURES

PHASE 2-2: SET THE THROTTLE CABLE



INSTRUCTIONS: KAWASAKI (ALL THE FOURTH STROKE)

1. SET THE THROTTLE OF THE FLYBOARD IN PARALLEL WITH THE THROTTLE OF THE PWC USING THE PART ITEM.138
2. INSERT A HOSE CLAMP TO ATTACH THE TWO WIRES TOGETHER AS SHOWN IN THE PICTURES

PHASE 2-2: SET THE THROTTLE CABLE



176

138

135



INSTRUCTIONS: YAMAHA

1. SET THE THROTTLE OF THE FLYBOARD IN PARALLEL WITH THE THROTTLE OF THE PWC USING THE PART ITEM.138
2. INSERT A HOSE CLAMP TO ATTACH THE TWO WIRES TOGETHER AS SHOWN IN THE PICTURES

PHASE 2-3: PULLEY ADJUSTMENT

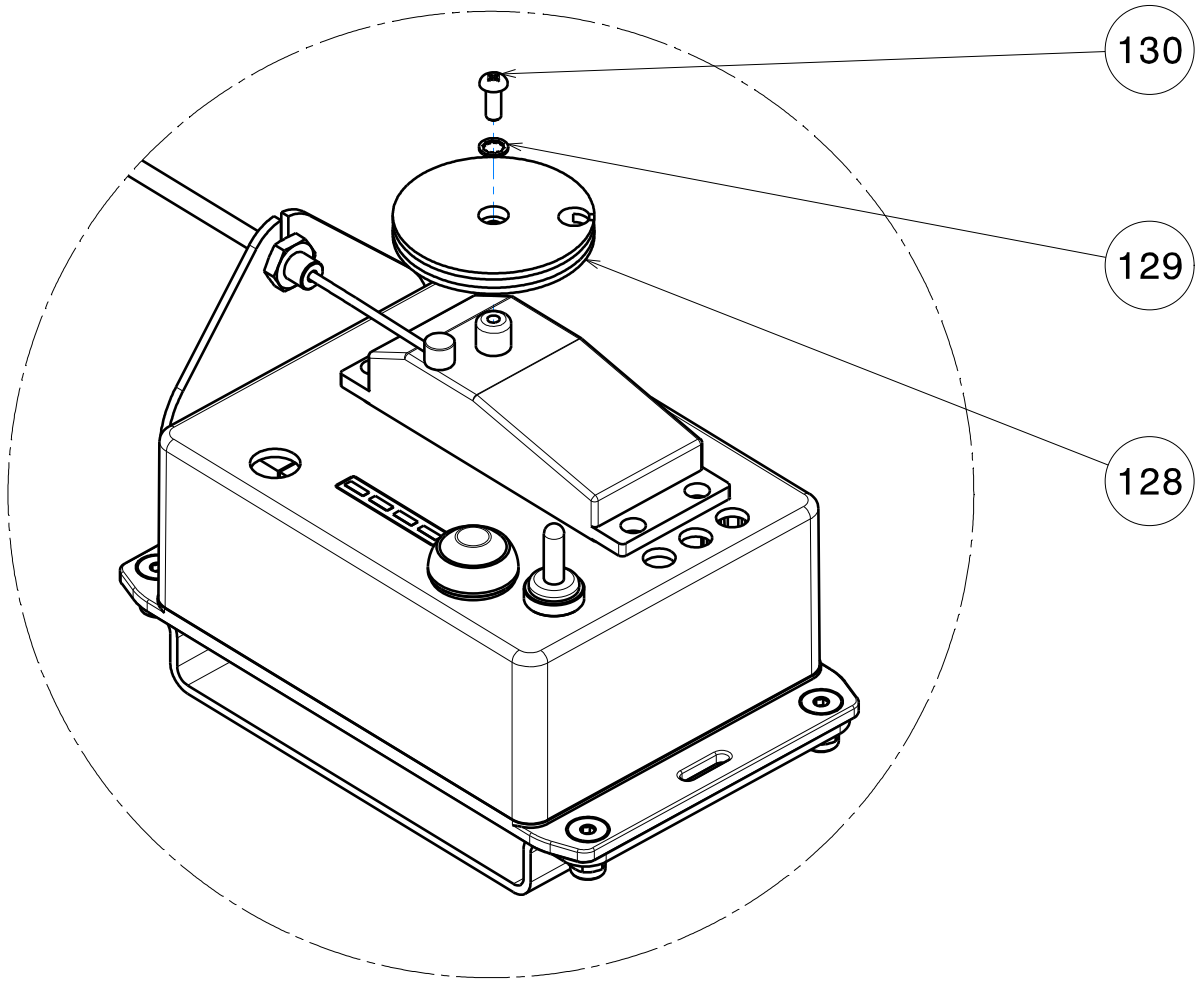

INSTRUCTIONS:

PERFORM TENSION ADJUSTMENT BY ROTATING THE PULLEY ITEM.128 ON THE DRIVE, MAKE FINE ADJUSTMENTS USING THE NUTS ON BOTH SIDES OF THE THROTTLE CABLE

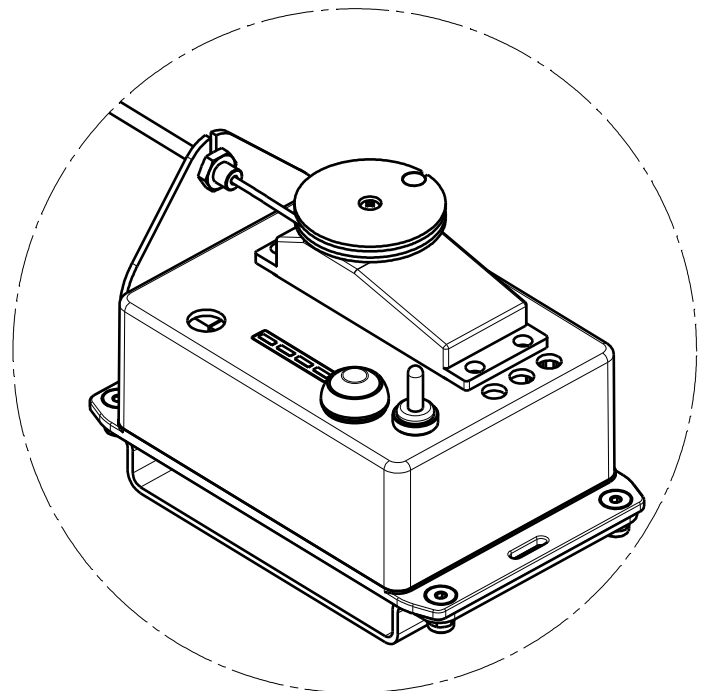
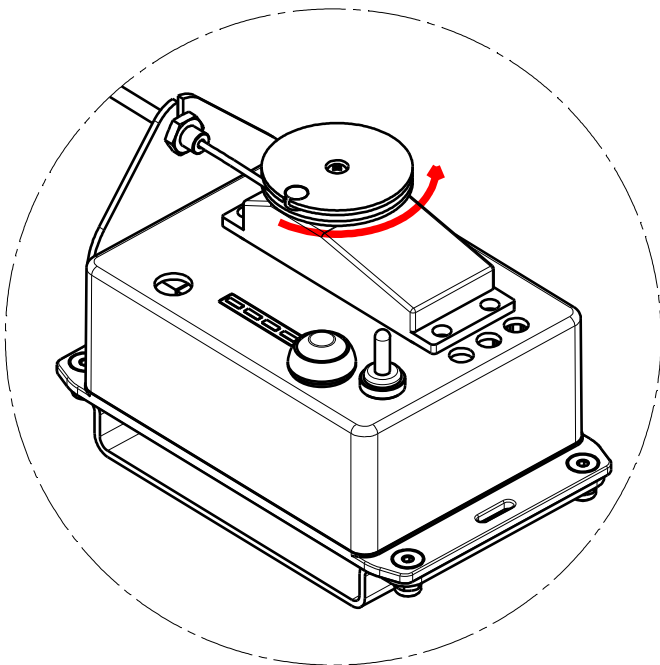

PHASE 3-1: SET THE UNIVERSAL KIT

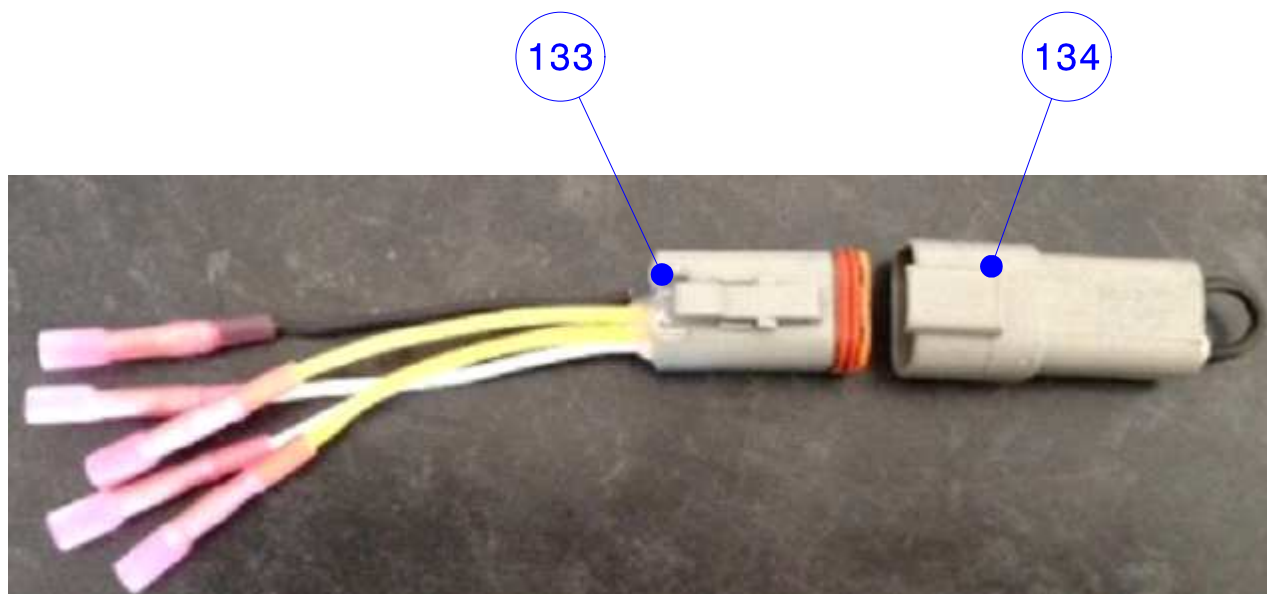

CRIMPING



SLAKE THE PODS

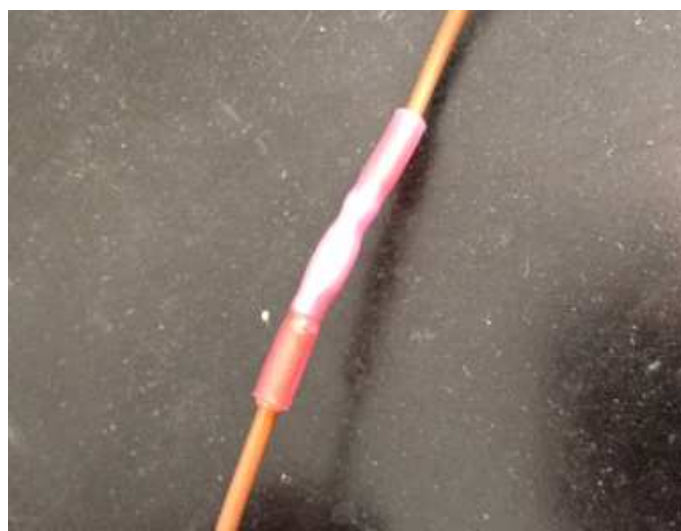

INSTRUCTIONS:

SET THE UNIVERSAL HARNESS ON THE PWC REFERRING TO THE APPROPRIATE ASSEMBLY SHEET.

1. CRIMP ALL THE PODS TO ENSURE ELECTRICAL CONTINUITY
2. RETRACT THE RED PODS WITH A LIGHTER OR A HOT AIR BLOWER TO SLAKE THE CONNECTION

PHASE 3-2: BEAM ADAPTATION ON PWC

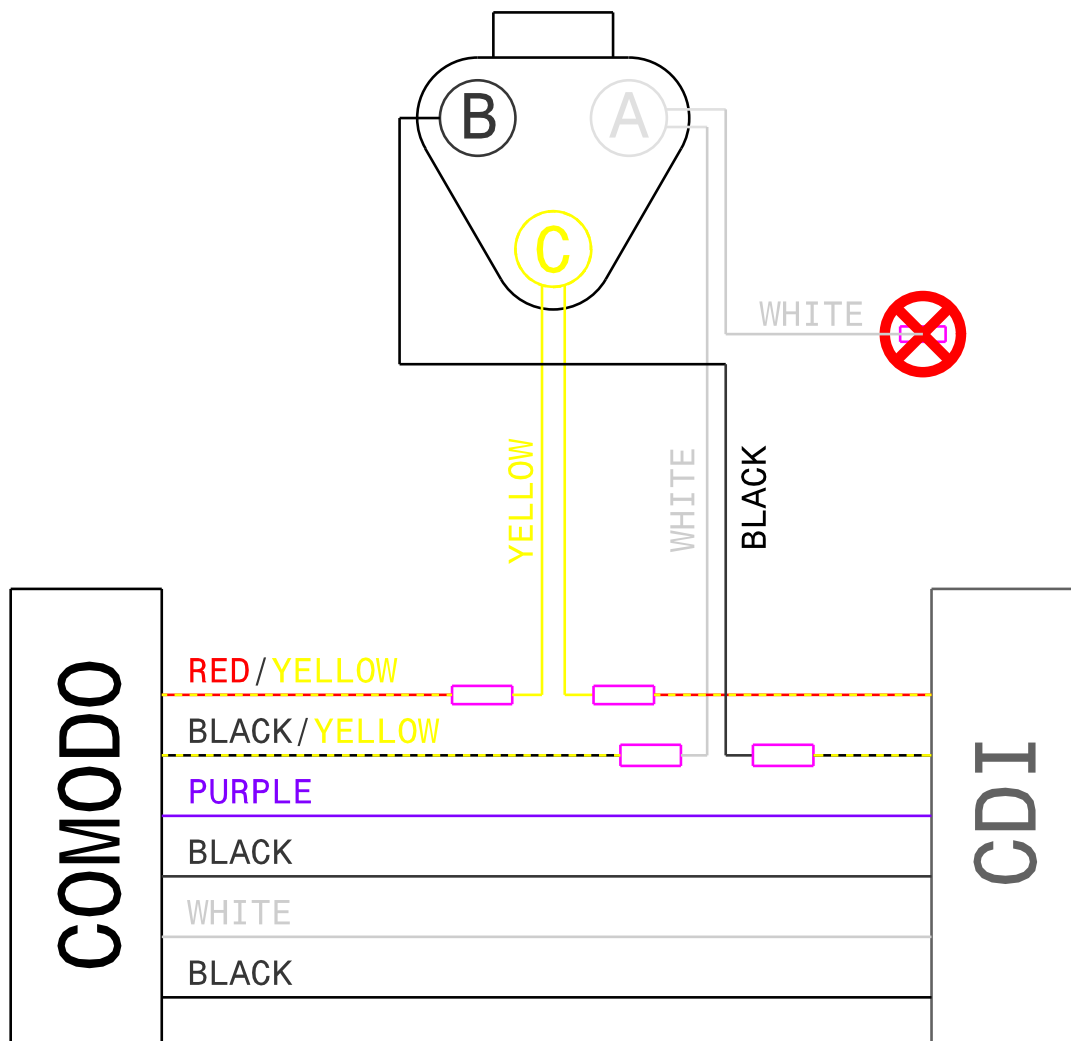

INSTRUCTIONS: SEAD00

1. CUT THE YELLOW AND BLACK WIRE UPSTREAM GREY MALE 6 WAY POD - STRIP THE TWO SIDES OF THE WIRE – CRIMP AND SLAKE
2. CUT THE YELLOW AND RED WIRE UPSTREAM OF THE SAME GREY POD- STRIP THE TWO SIDES OF THE WIRE – CRIMP AND SLAKE THE 2 ROSE PODS OF THE YELLOW WIRES OF THE ADAPTER.
3. RETRACT THE ROSE POD OF THE WHITE WIRE TO ISOLATE IT

PHASE 3-2: BEAM ADAPTATION ON PWC

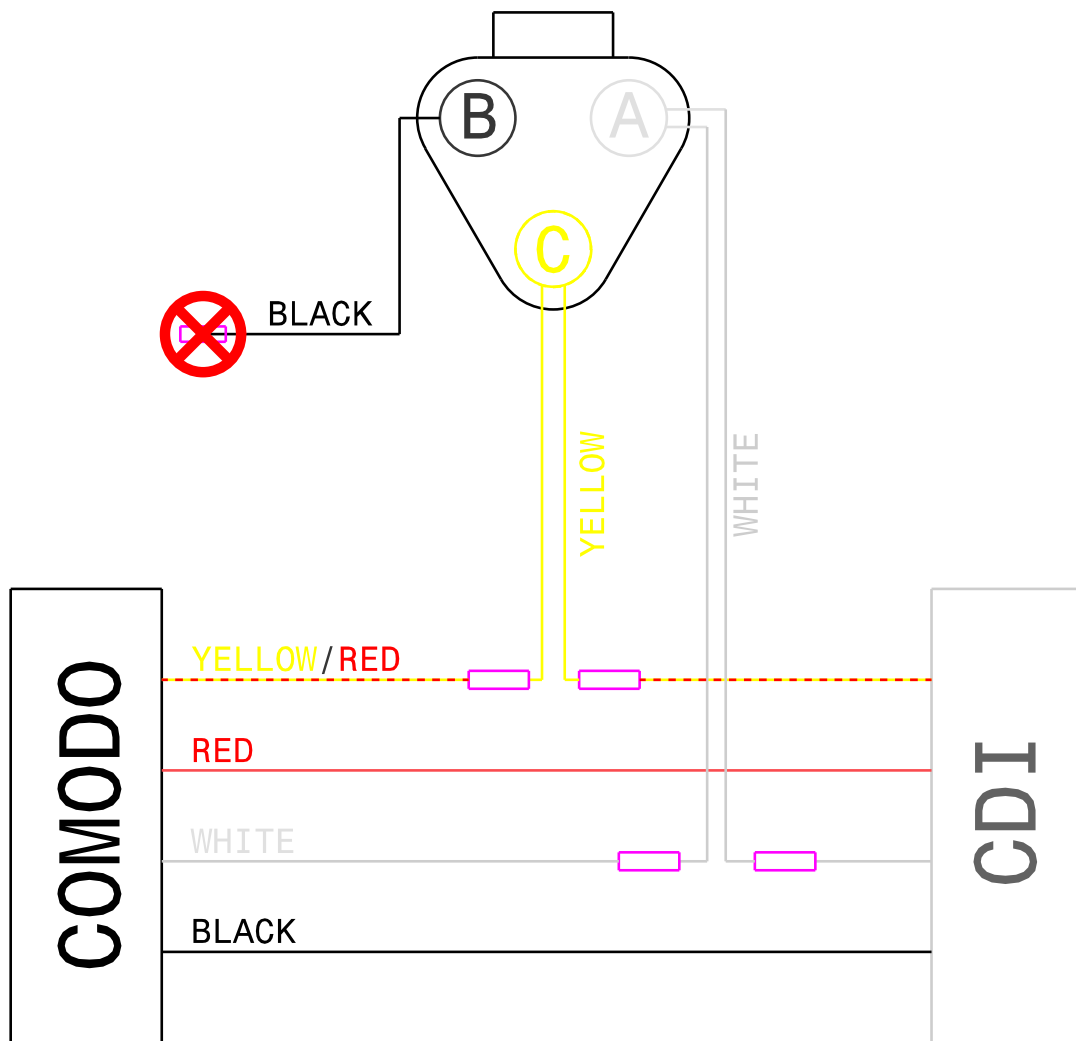

INSTRUCTIONS: KAWASAKI

1. CUT THE WHITE WIRE UPSTREAM OF WHITE MALE POD - STRIP THE TWO SIDES OF THE WIRE - CRIMP AND SLAKE THE 2 ROSE PODS OF THE WHITE WIRE OF THE ADAPTER
2. CUT THE YELLOW/RED WIRE UPSTREAM OF THE WHITE MALE POD - EXPOSE THE 2 SIDES OF THE WIRE - CRIMP AND SLAKE THE 2 ROSE PODS OF THE YELLOW WIRE OF THE ADAPTER
3. RETRACT THE ROSE POD OF THE BLACK WIRE TO ISOLATE IT

PHASE 3-2: BEAM ADAPTATION ON PWC

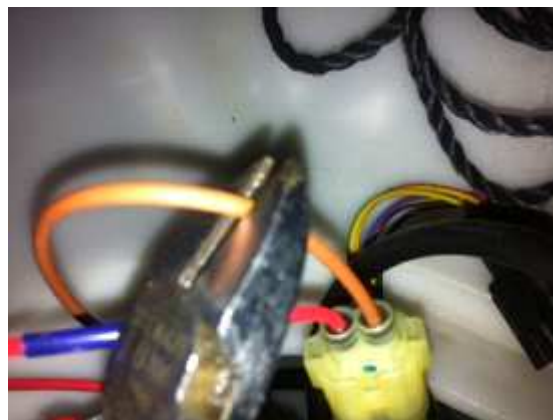
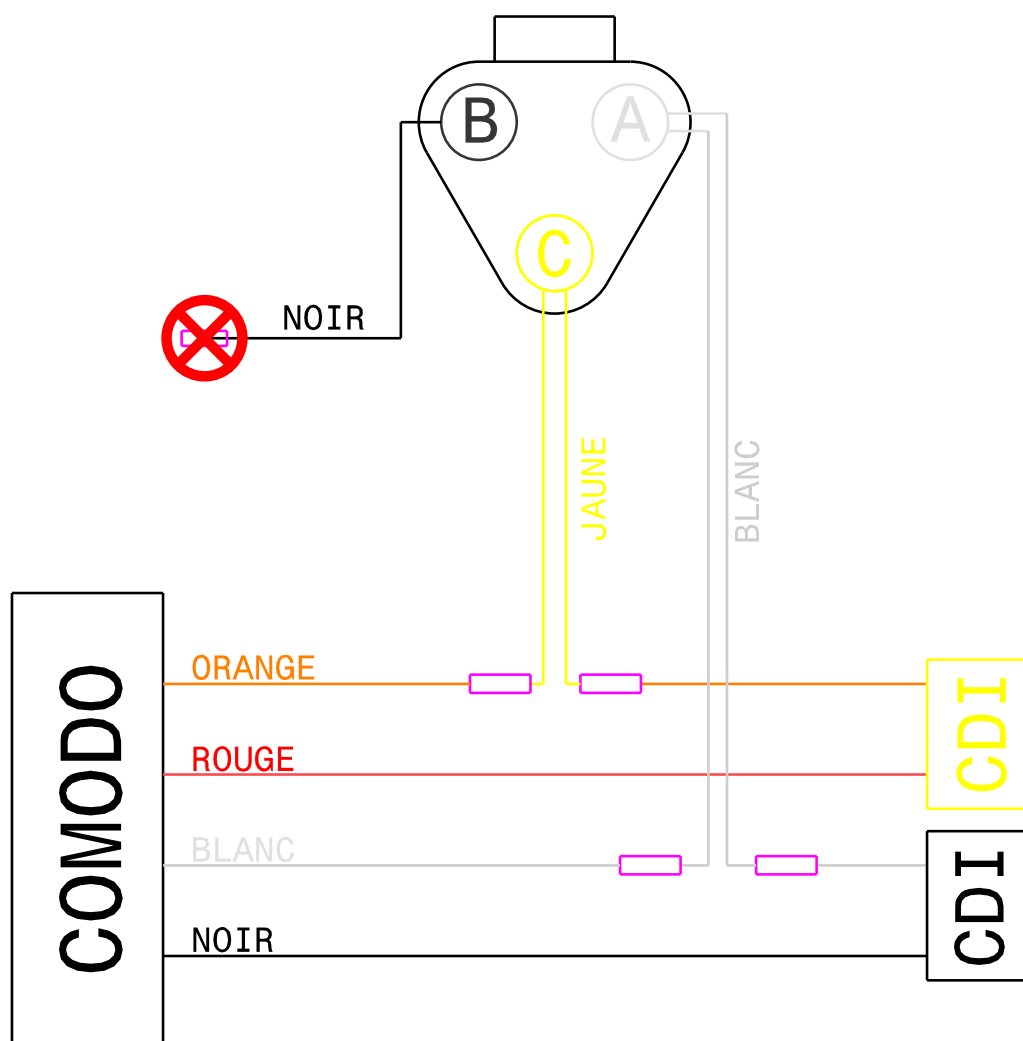

INSTRUCTIONS: YAMAHA

1. CUT THE WHITE WIRE UPSTREAM OF BLACK MALE POD - STRIP THE TWO SIDES OF THE WIRE - CRIMP AND SLAKE THE 2 RED PODS OF THE WHITE WIRE OF THE ADAPTER
2. CUT THE ORANGE WIRE UPSTREAM OF THE YELLOW MALE POD - EXPOSE THE 2 SIDES OF THE WIRE - CRIMP AND SLAKE THE 2 RED PODS OF THE YELLOW WIRE OF THE ADAPTER
3. RETRACT THE ROSE POD OF THE BLACK WIRE TO ISOLATE IT

PHASE 4-1: CONNECTION OF THE ELECTRONIC BOX

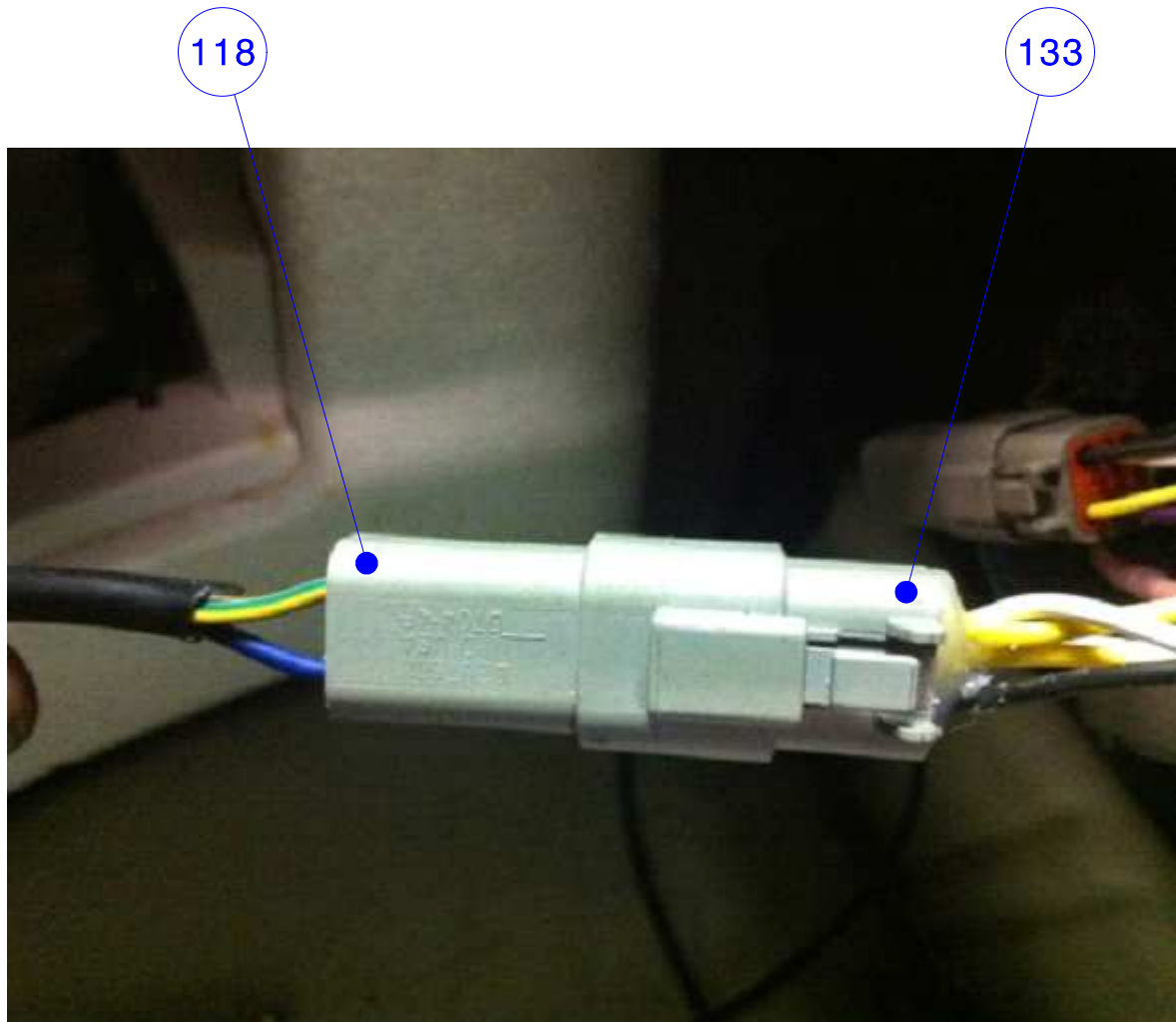

INSTRUCTIONS:

CONNECT THE GREY FEMALE 3-WAY LUG OF THE HOUSING TO THE MALE 3-WAY LUG OF THE ADAPTER PREVIOUSLY INSTALLED ON THE PWC

PHASE 5-1: GROUND THE FLYBOARD



135

136

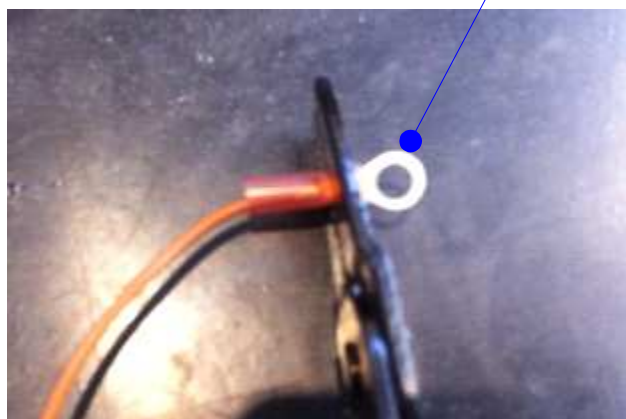

INSTRUCTIONS:

1. CONNECT THE CABLE ITEM.135 TO THE BOLT OF THE PUMP
2. DRILL A HOLE IN THE TURBINE SHAFT OF THE PWC (DIAMETER 2.5) TO RECOVER THE BROWN WIRE INSIDE THE ENGINE COMPARTMENT THEN MAKE WATERPROOF WITH SILICONE MARINE.
3. CRIMP THE POD DIAMETER 6 ITEM.136 TO THE CABLE ITEM.135
4. RETRACT TO MAKE IT WATERPROOF
5. CONNECT THE EYLET $\phi 6$ TO ANY BOLT OF THE ENGINE AS IT IS NOT ISOLATED FROM THE GROUND

PHASE 6-1: DRILLING THE ELBOW

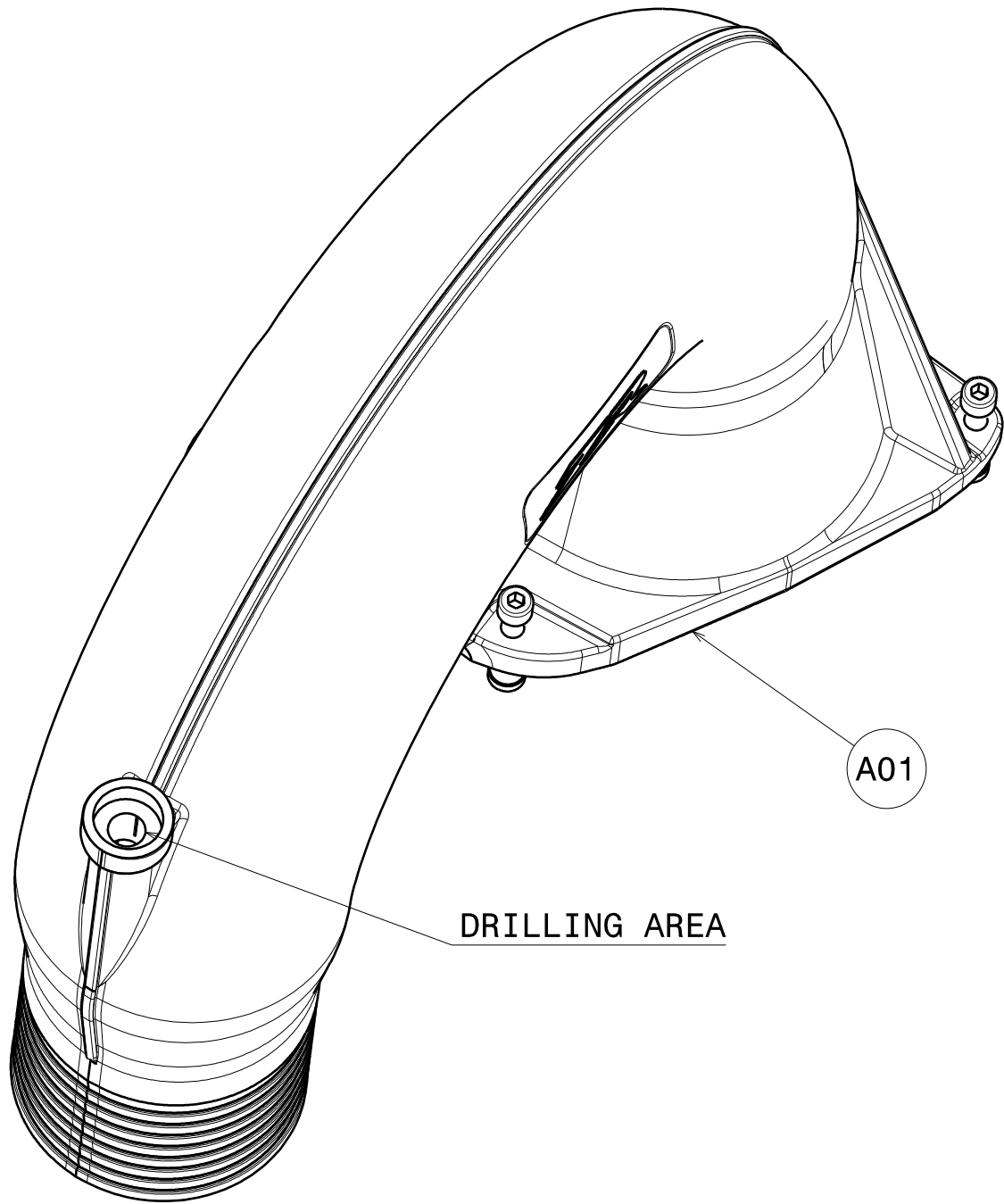

INSTRUCTIONS:
DRILL THE ELBOW ITEM A01

PHASE 6-2: INSERTION OF SIGNAL BEAM

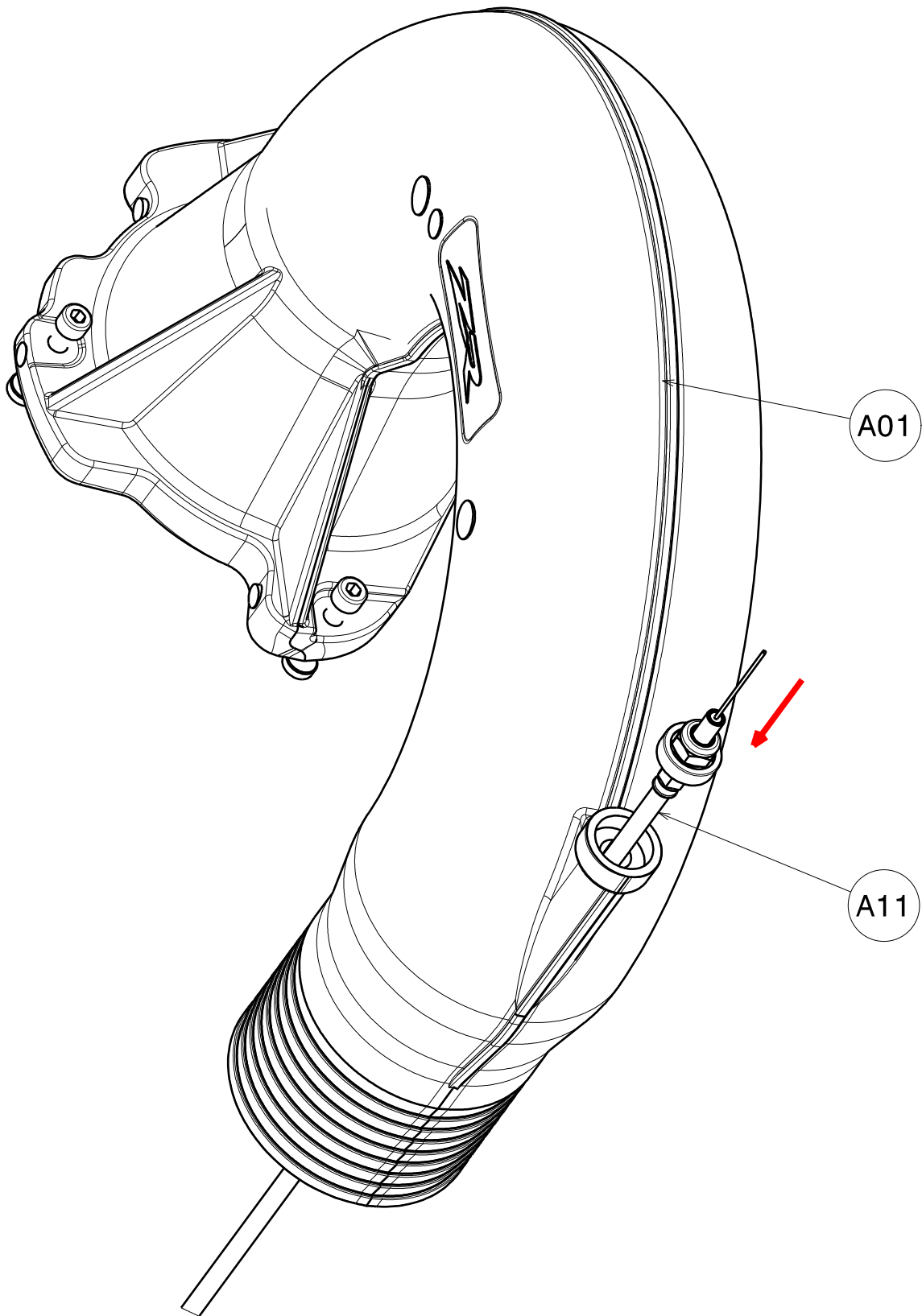

INSTRUCTIONS:

INSERT ONE END OF THE CABLE ITEM.A11 INSIDE THE ELBOW ITEM.A01

PHASE 6-3: SETTING UP THE BEARING

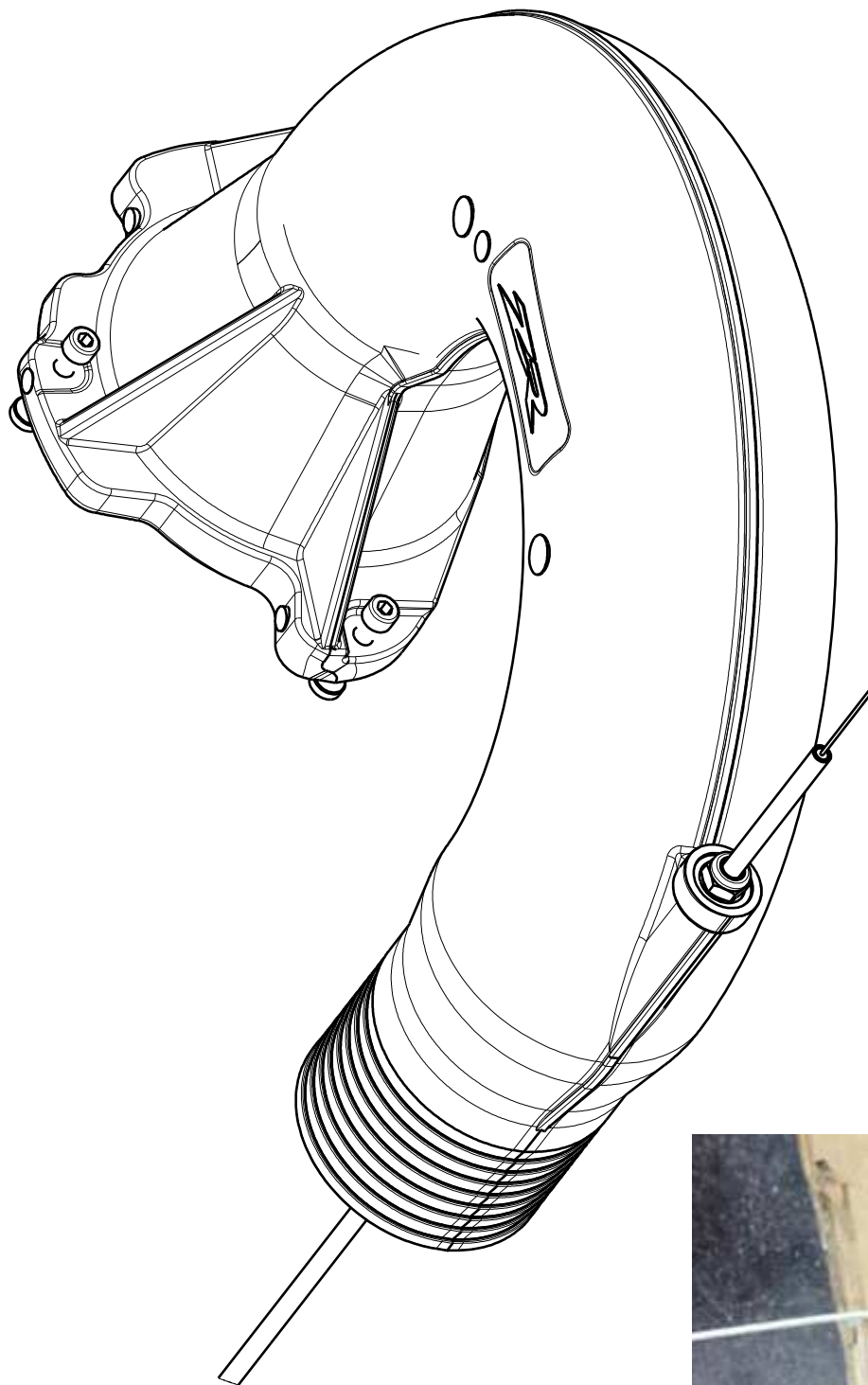

INSTRUCTIONS:

1. STICK THE BEARING WITH A BLOCK PRESS, WITH ONLY 2 POINTS OF GLUE TO PREVENT THE ELECTRICAL CONNECTION BETWEEN THE ELBOW AND THE BEARING
2. PUSH THROUGH THE BEARING IN THE HOUSING PROVIDED FOR THIS PURPOSE USING A MALLET
3. PASS THE ELECTRONIC CABLE INSIDE THE HOSE N° 005 AND THROUGH THE SPARES ITEM.A03, 021, A04

PHASE 6-4: REMOVE THE NOZZLE CAP

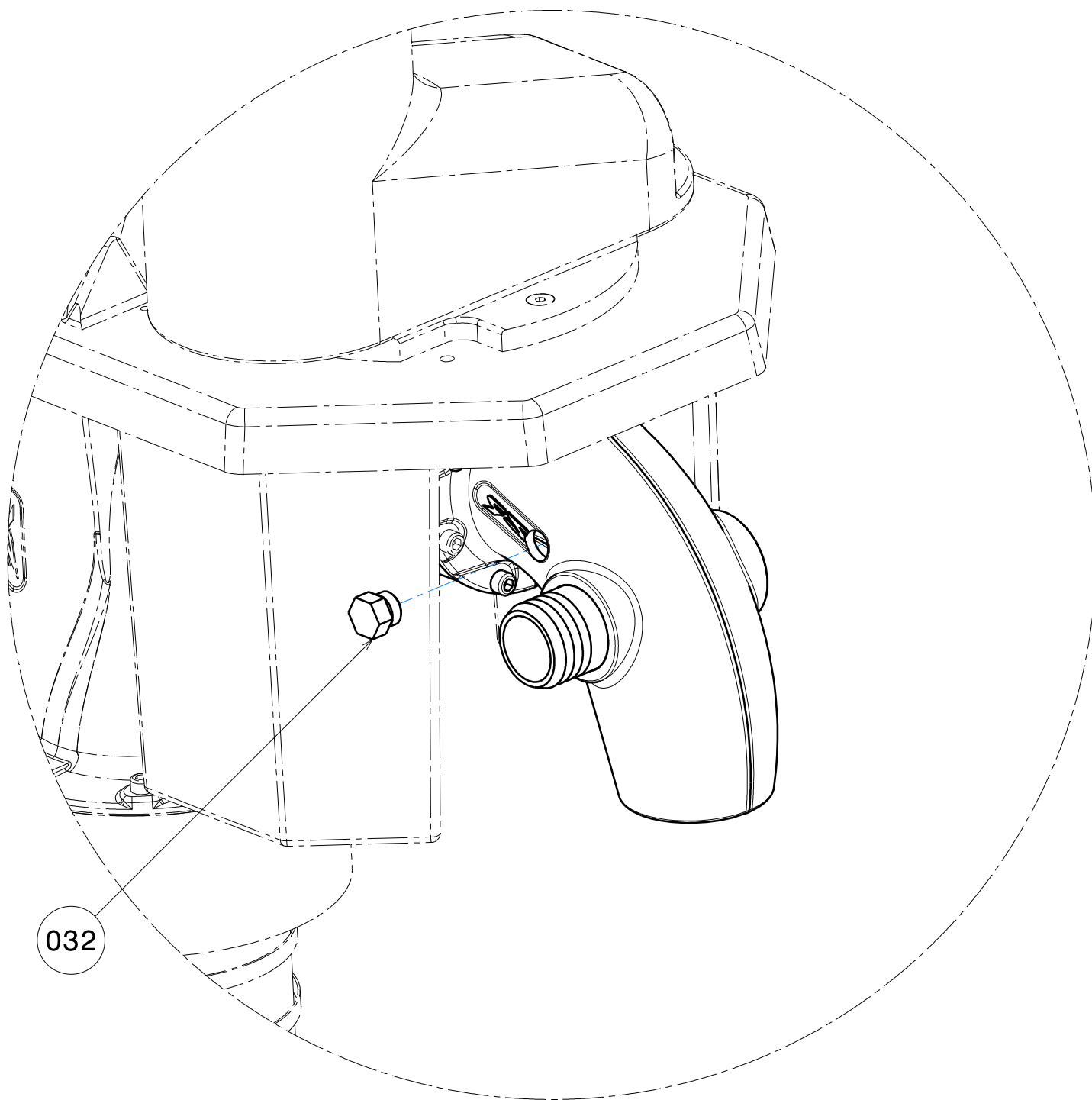

INSTRUCTIONS:
REMOVE THE RIGHT HAND NOZZLE CAP ITEM.032

PHASE 6-5: CABLE INSERTION INSIDE THE NOZZLE

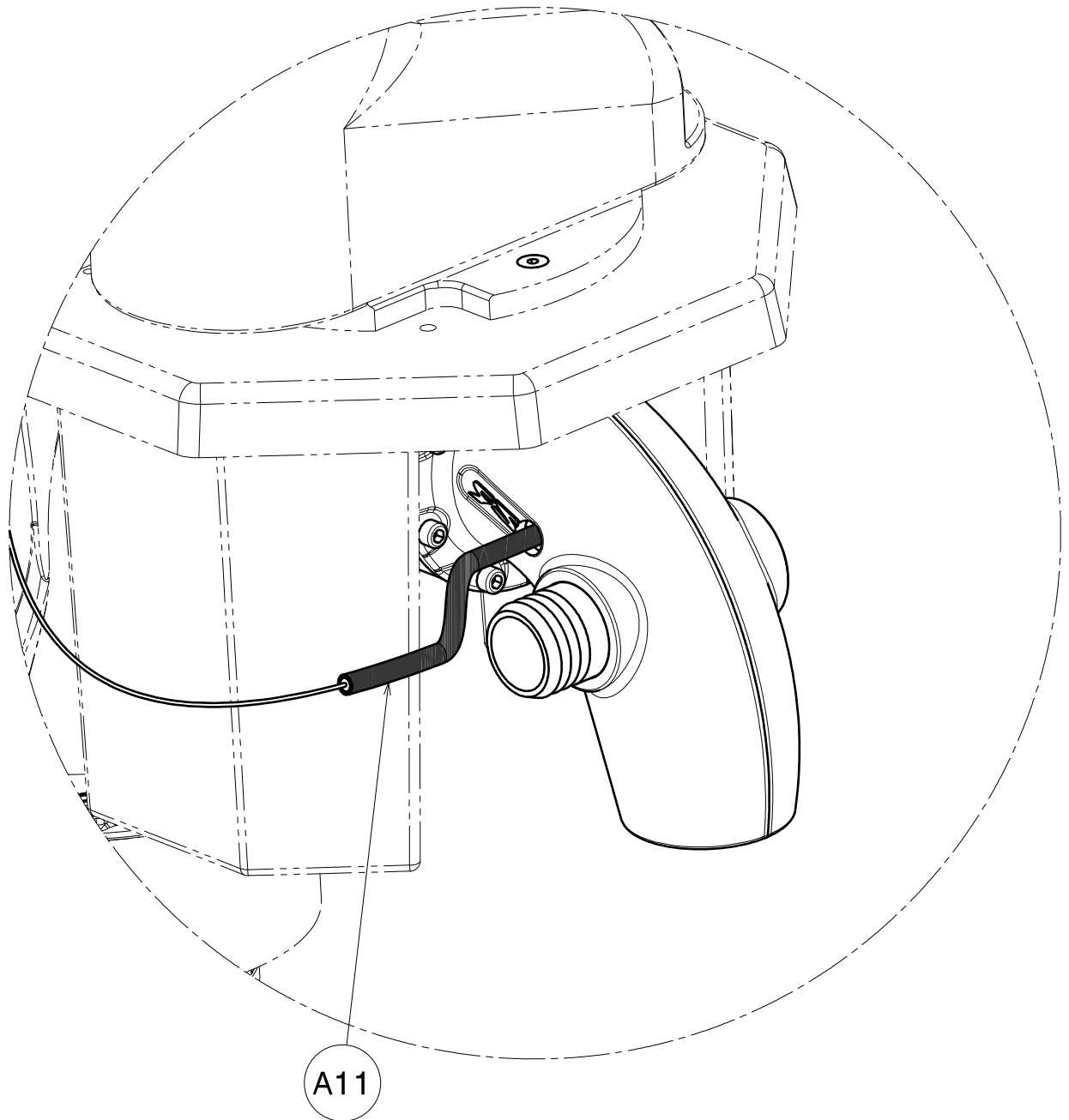

INSTRUCTIONS:

REMOVE THE CABLE THROUGH THE THREADED HOLE OF THE RIGHT HAND NOZZLE

PHASE 6-6: POSITION THE GLAND

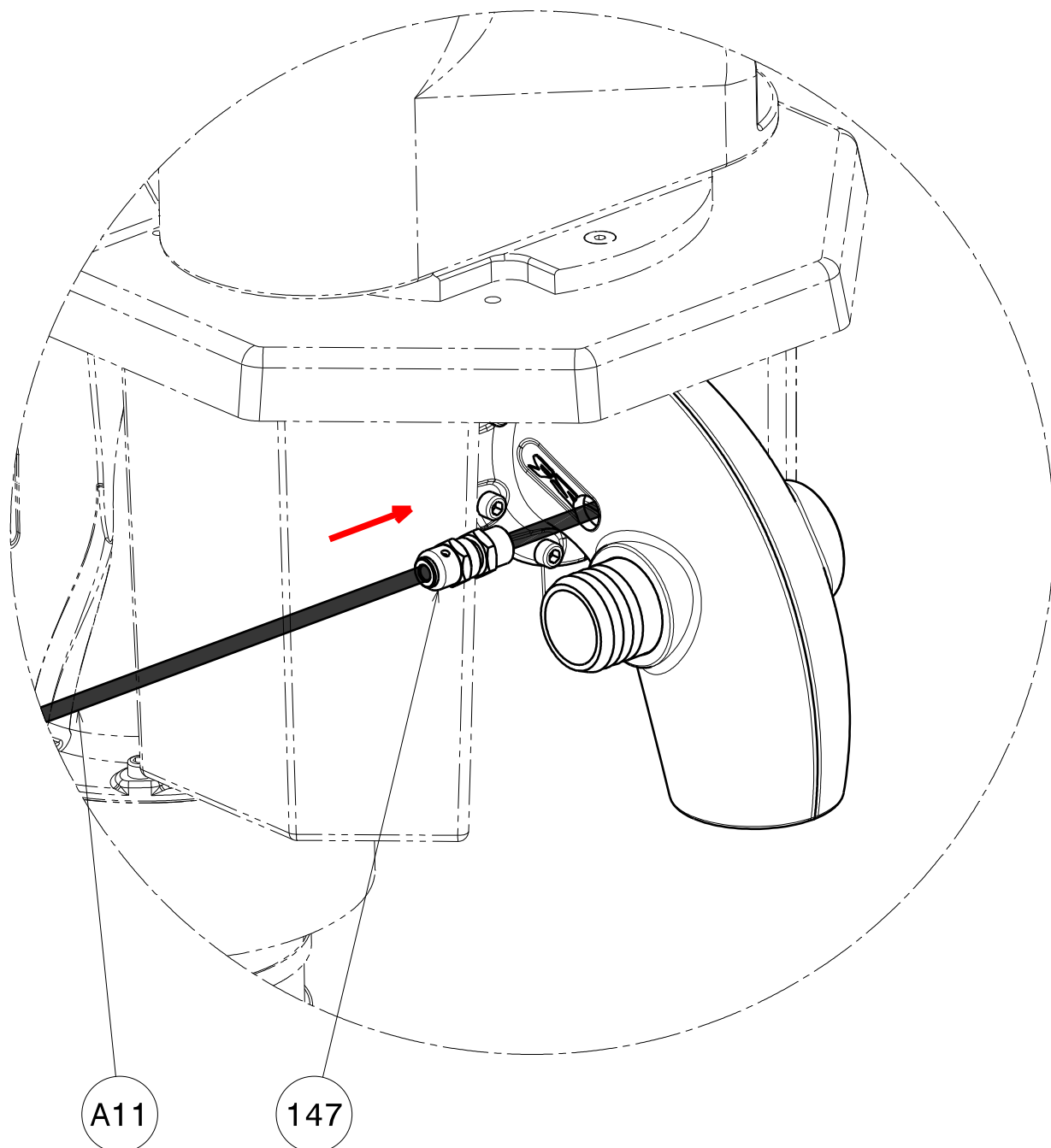

INSTRUCTIONS:

1. INSERT THE CABLE ITEM.A11 OF THE THE GLAND ITEM.147
2. SCREW THE GLAND INTO THE THREAD OF THE NOZZLE

PHASE 6-7: ADJUSTING THE LENGTH 1



INSTRUCTIONS:

1. TENSION THE HOSE OF THE FLYBOARD IN ORDER TO HAVE NO TWIST BETWEEN THE FLYBOARD AND THE ELBOW N°REP.A01
2. PULL MODERATELY ON THE CABLE TO TENSE IT INSIDE THE HOSE

PHASE 6-8: ADJUSTING THE LENGTH 2

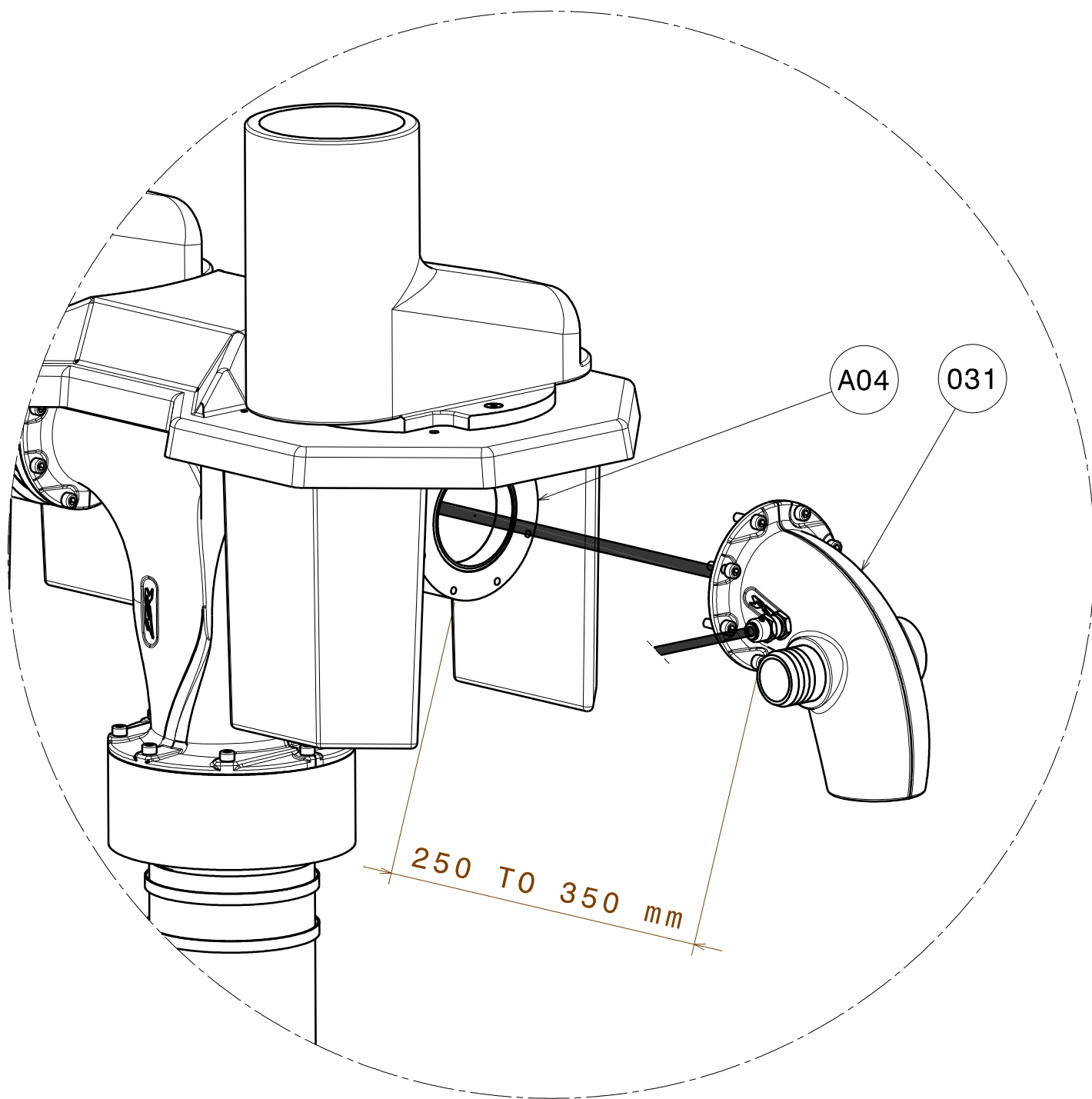

INSTRUCTIONS:

TIGHTEN THE GLAND LETTING A 25 TO 35 CM DISTANCE BETWEEN THE RIGHT HAND NOZZLE ITEM.031 AND THE LEFT PIVOTAL TUBE ITEM.A04

WARNING: AN IMPROPER ADJUSTMENT CAUSES IRREVERSIBLE DAMAGE ON THE CABLE!

PHASE 6-9: GROUND THE NOZZLE

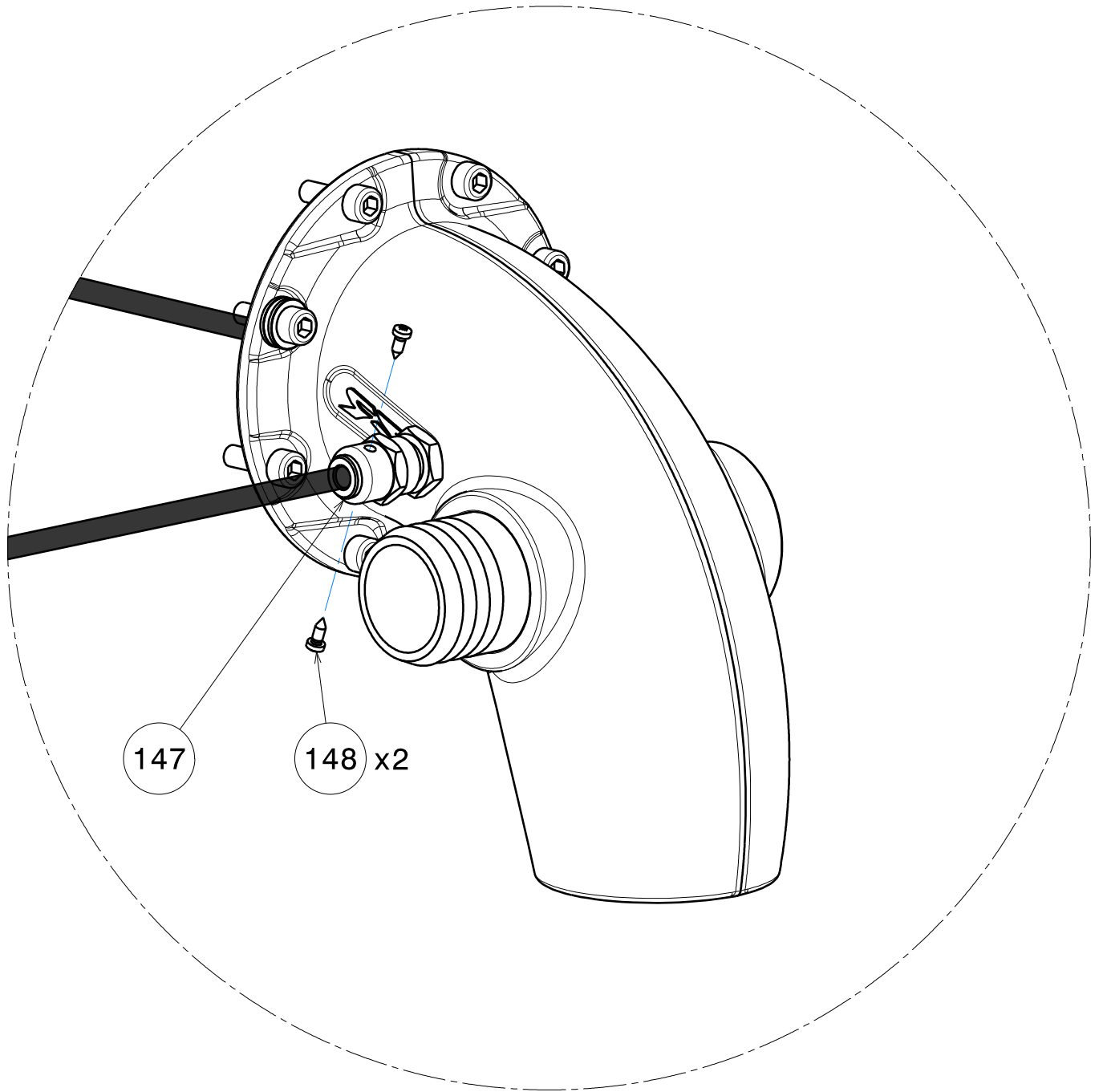

INSTRUCTIONS:

SCREW THE LITTLE SCREWS ITEM.148 IN THE GLAND ITEM.147

PHASE 6-10: CHECKING THE GROUND



INSTRUCTIONS:

CHECK THE ELECTRIC CONTINUITY BETWEEN THE ELBOW AND THE GLAND WITH A MULTIMETER

PHASE 6-11: TRIGGER ASSEMBLY ON THE HANDLE

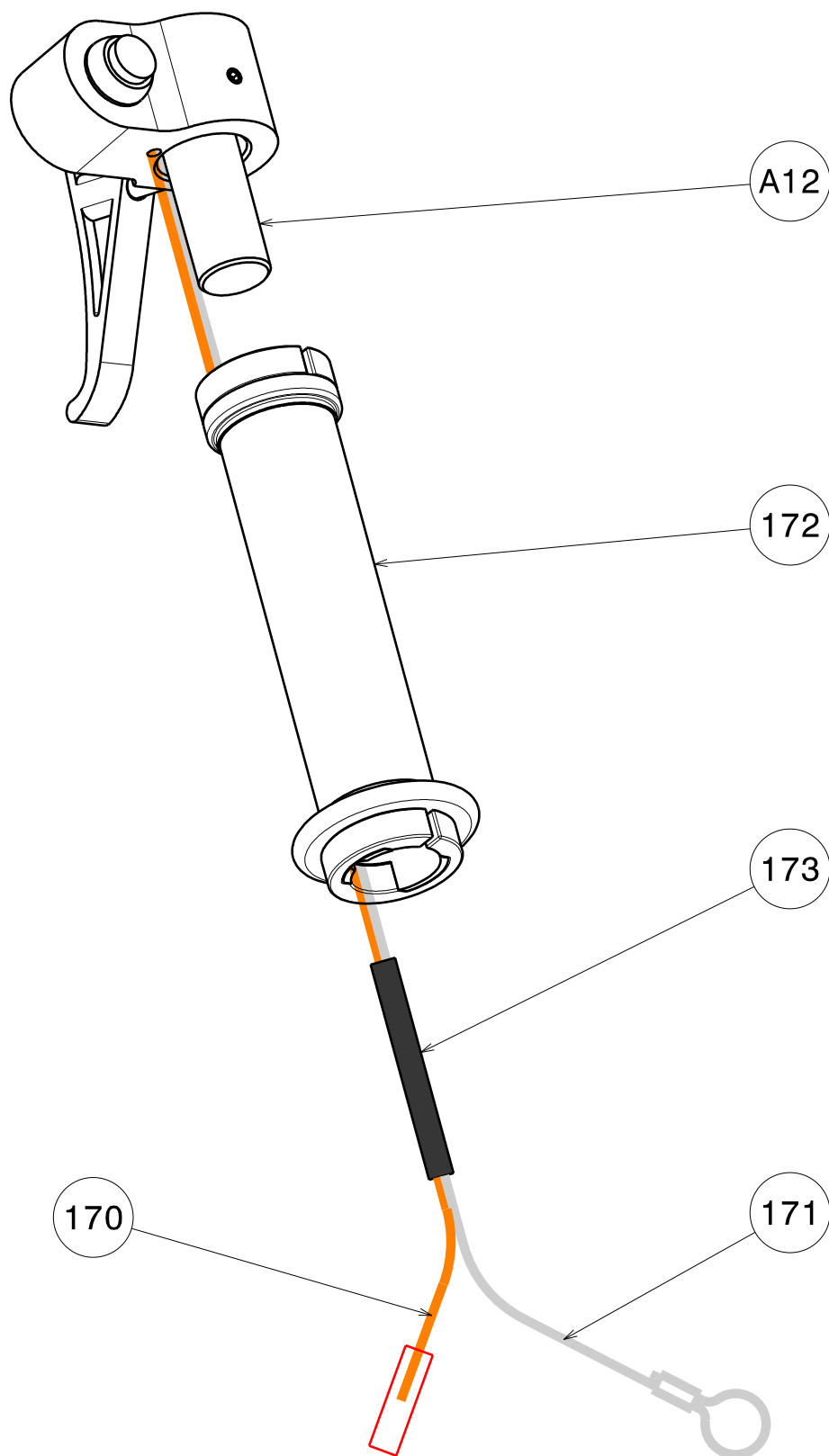

INSTRUCTIONS:

INSERT THE ORANGE WIRE AND THE STAINLESS STEEL CABLE OF THE TRIGGER ITEM.A12 INSIDE THE GROOVED HANDLE ITEM.172 THEN IN THE INSIDE THE THERMO RETRACTABLE SHEATH ITEM.173

PHASE 6-12: GROUND THE TRIGGER

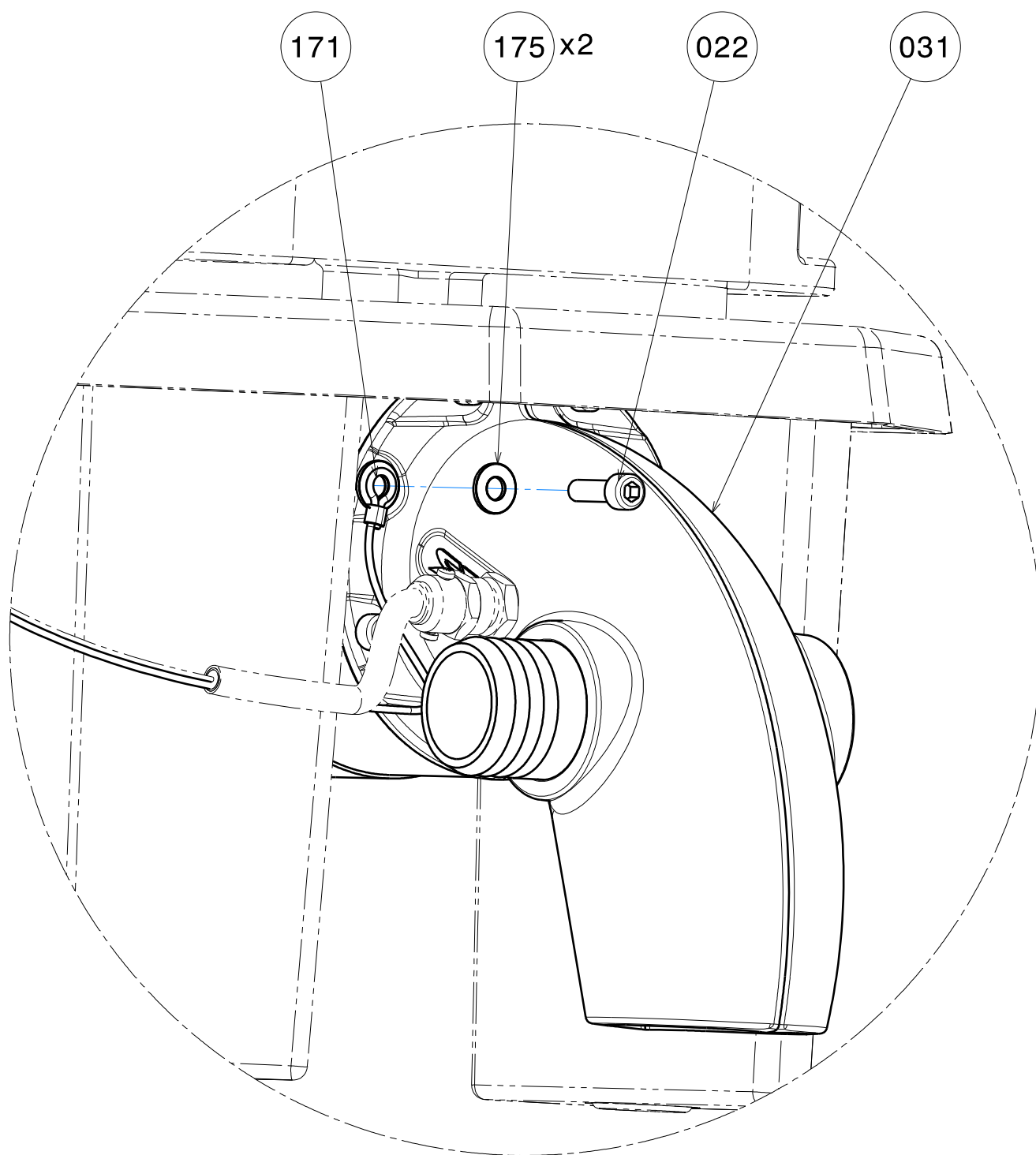

INSTRUCTIONS:

CONNECT THE PART ITEM.171 TO THE NOZZLE ITEM.031
PINCH PART ITEM.171 BETWEEN THE 2 WASHERS ITEM.175 AND PUT ALL BETWEEN
THE SCREW ITEM.022 AND THE NOZZLE

PHASE 6-13: PREPARING TRIGGER ASSEMBLY

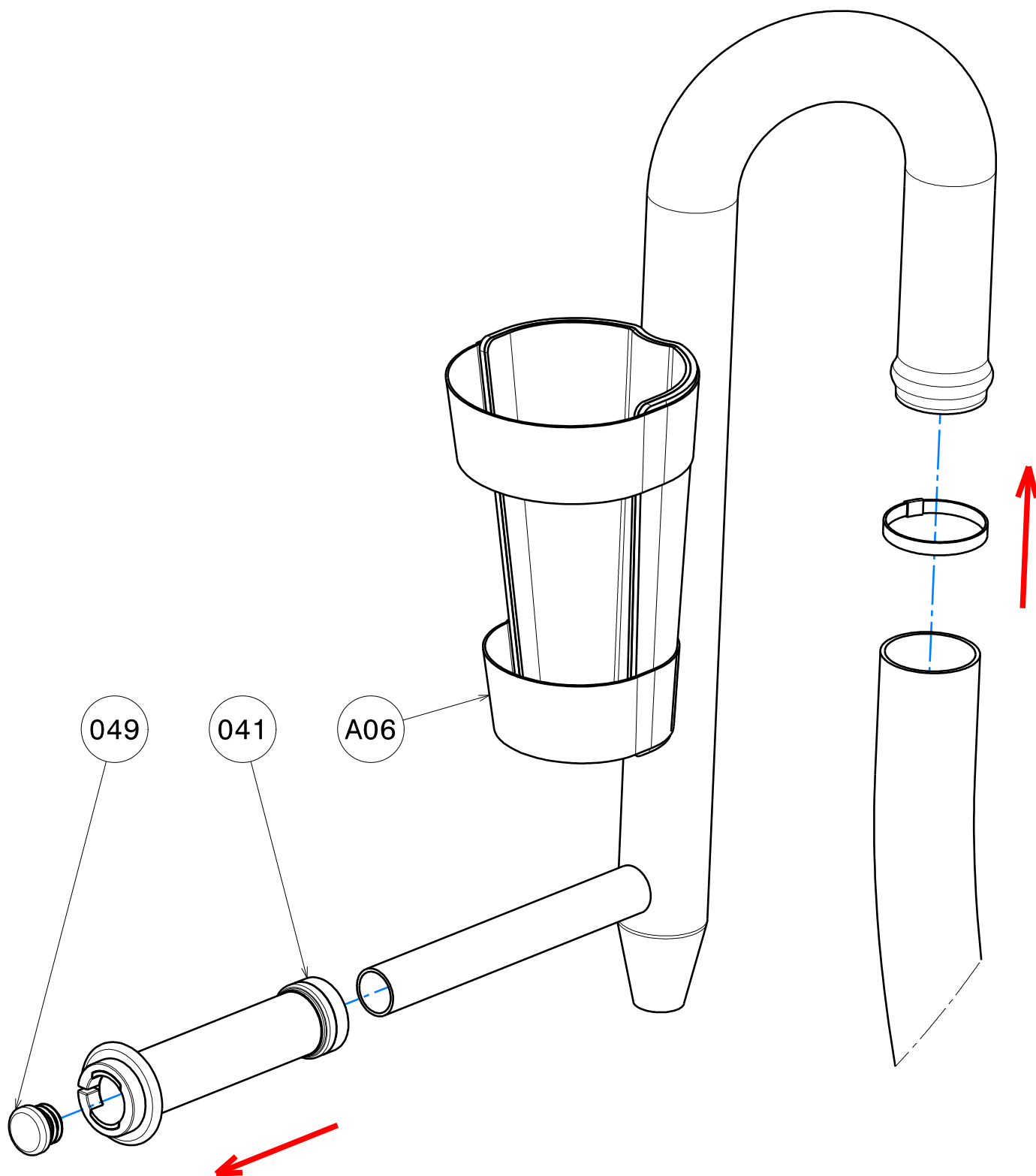

INSTRUCTIONS:

REMOVE THE CAP ITEM.049 AND THE HANDLE ITEM.041
REMOVE THE RIGHT STABILIZER ITEM.A06 FROM HIS HOSE

PHASE 6-14: ADJUSTING THE LENGTH 3

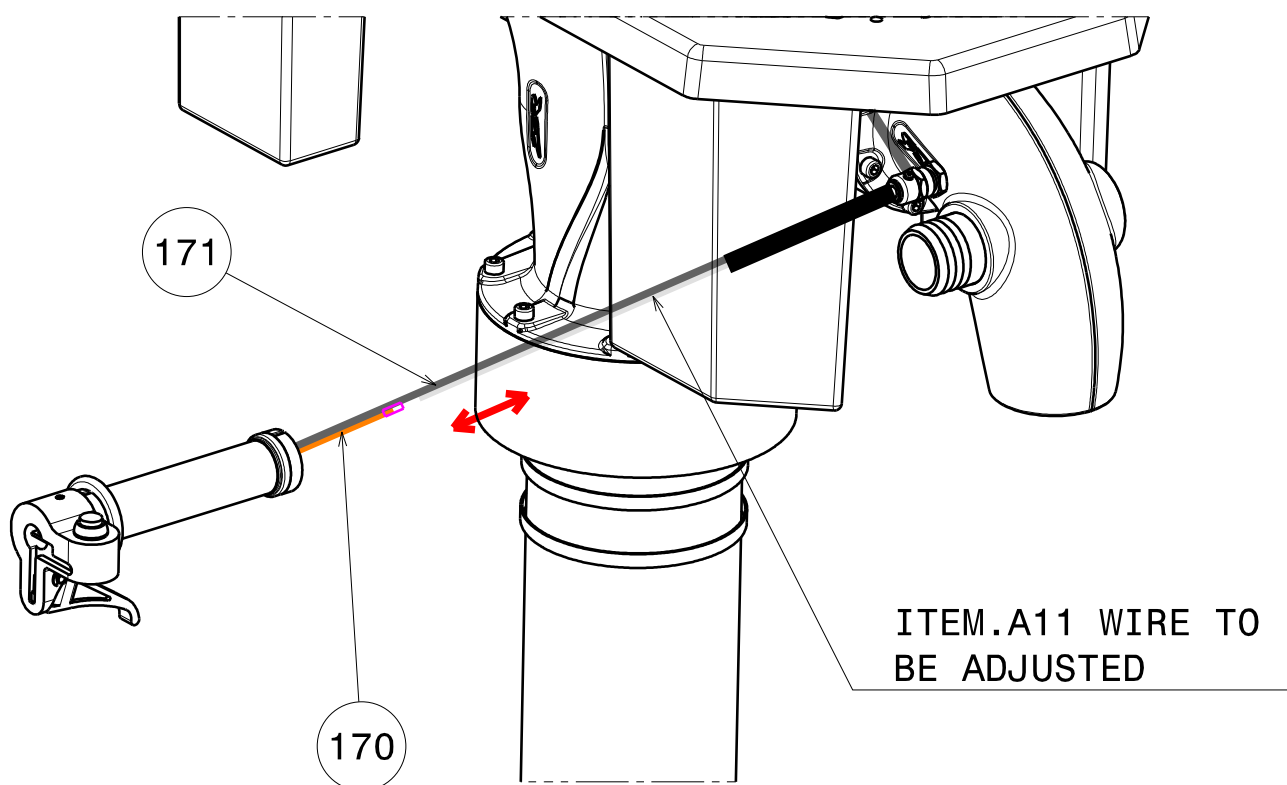

INSTRUCTIONS:

PULL THE CABLE COMING OUT OF THE ELBOW ITEM.A01 TO EQUALIZE THE TWO LENGTH OF THE CABLES ITEM.A11 AND 171

IMPORTANT : THE RED HOSE ITEM.038 MUST BE STRETCHED AS IN THE PHASE 6-7 TO FACILITATE THE SLIDING OF THE CABLE IN THE SHEATH

PHASE 6-15: CONNECTION CABLE AND HOSE

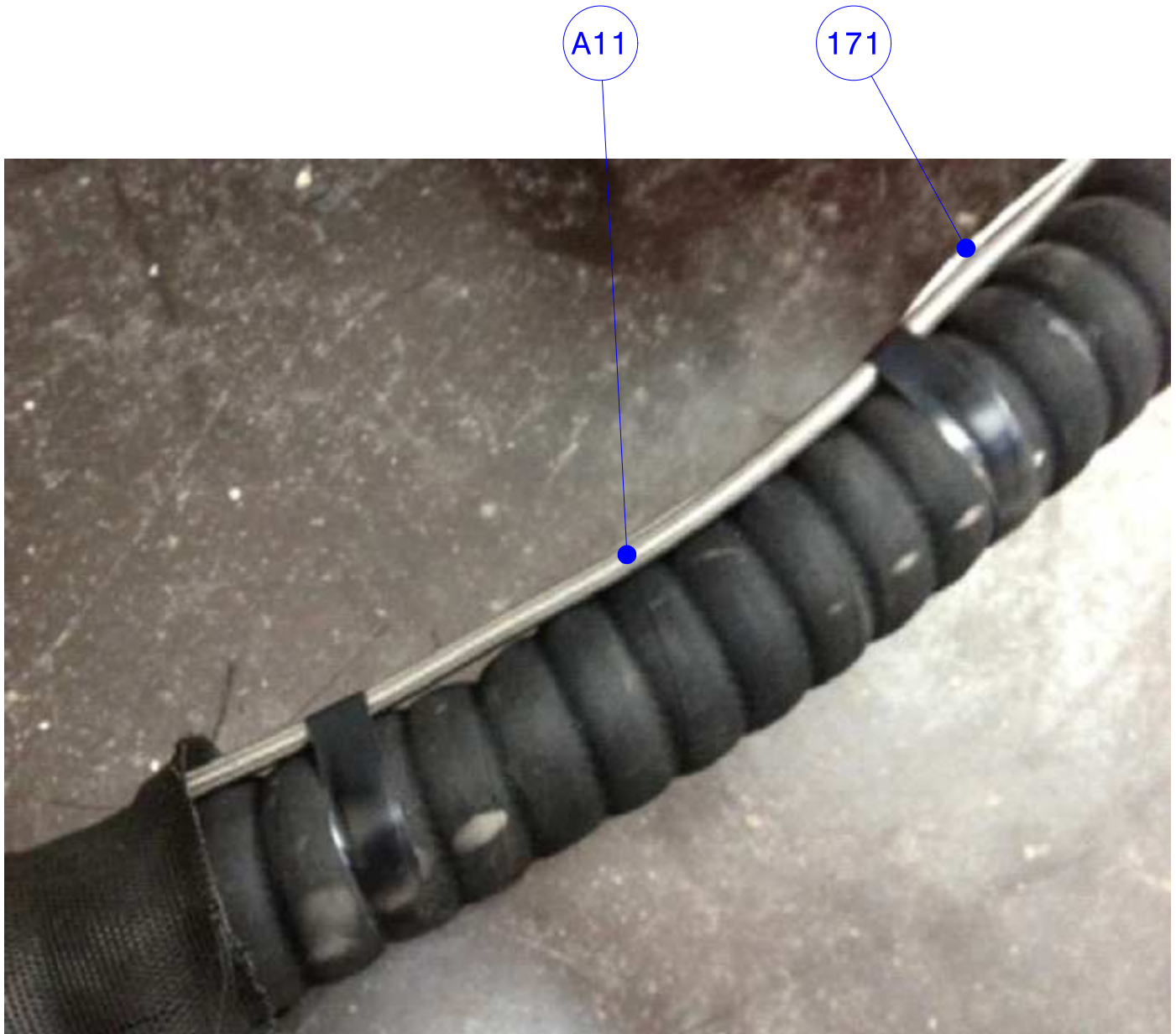

INSTRUCTIONS:

1. PUT THE HOSE ON THE NOZZLE WITH THE CLAMP
2. FIX THE STAINLESS STEEL CABLE ITEM.171 AND THE CABLE ITEM.A11 ON THE HOSE WITH A CHATTERTON

PHASE 6-16: CONNECTION TRIGGER'S SIGNAL



INSTRUCTIONS:

1. CRIMP THE RED POD OF THE ORANGE WIRE ITEM.171 ON THE STAINLESS STEEL CABLE COMING OUT.
2. THERMO RETRACT THE SHEATH ITEM.173 OVER THE RED POD AND THE STAINLESS STEEL CABLE

WARNING: DO NOT DRILL THE WATERPROOF PROTECTION IT MIGHT CAUSE THE ELECTROLYSIS AND DESTRUCTION OF THE ORANG WIRE. USE AN APPROPRIATE TOOL

PHASE 6-17: PROTECTION OF THE CABLE

174



INSTRUCTIONS:

PUT THE PROTECTION SOCK ITEM.174 OVER THE TRIGGER ITEM.A12 AND OVER THE SUPPLY PIPE

PHASE 6-18: HANDLE'S TUBE MODIFICATION



*****WARNING*****

THIS STEP IS THE MOST DIFFICULT OF THE ASSEMBLY OF THE ELECTRONIC KIT

CHAMFER THE TUBE OF THE HANDLE (NOT DONE DURING THE PRODUCTION FOR ESTHETIC REASONS)

- THICKNESS 1.5 CM
- 7 TENTH OR 8 TENTH BEFORE RADIUS
- 2-3 MM LENGHT ROUND

CHAMFER BEFORE INSERT THE ORANGE WIRE IN THE THROTTLE TO AVOID DAMAGES ON IT

IF DAMAGED IT WILL BE DESTROYED BY ELECTROLISYS

PHASE 6-19: ASSEMBLY ON THE STABILIZER

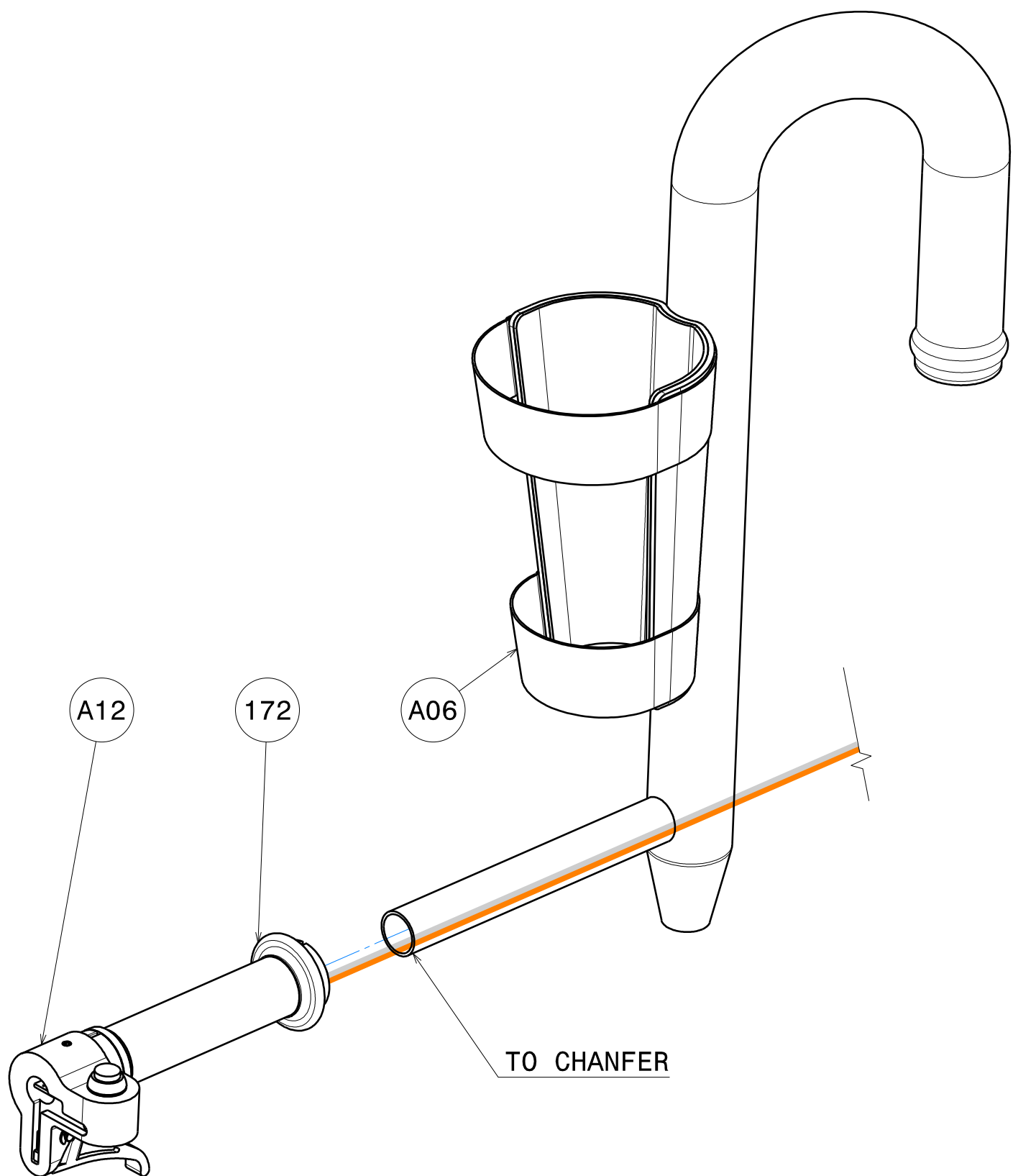

INSTRUCTIONS:

INSERT THE HANDLE ITEM.172 AND THE TRIGGER ITEM.A12 IN THE RIGHT STABILIZER. BE SURE THAT THE 2 WIRES ARE IN THE GROOVE CUT INTO THE HANDLE REMOVE THE SCREW AND SPREAD LIGHTLY WITH A SCREW DRIVER USE OF MARINE GREASE FOR PROPER SLIDE WHEN INSERTING THE HANDLE

PHASE 6-20: FIXING THE CABLE

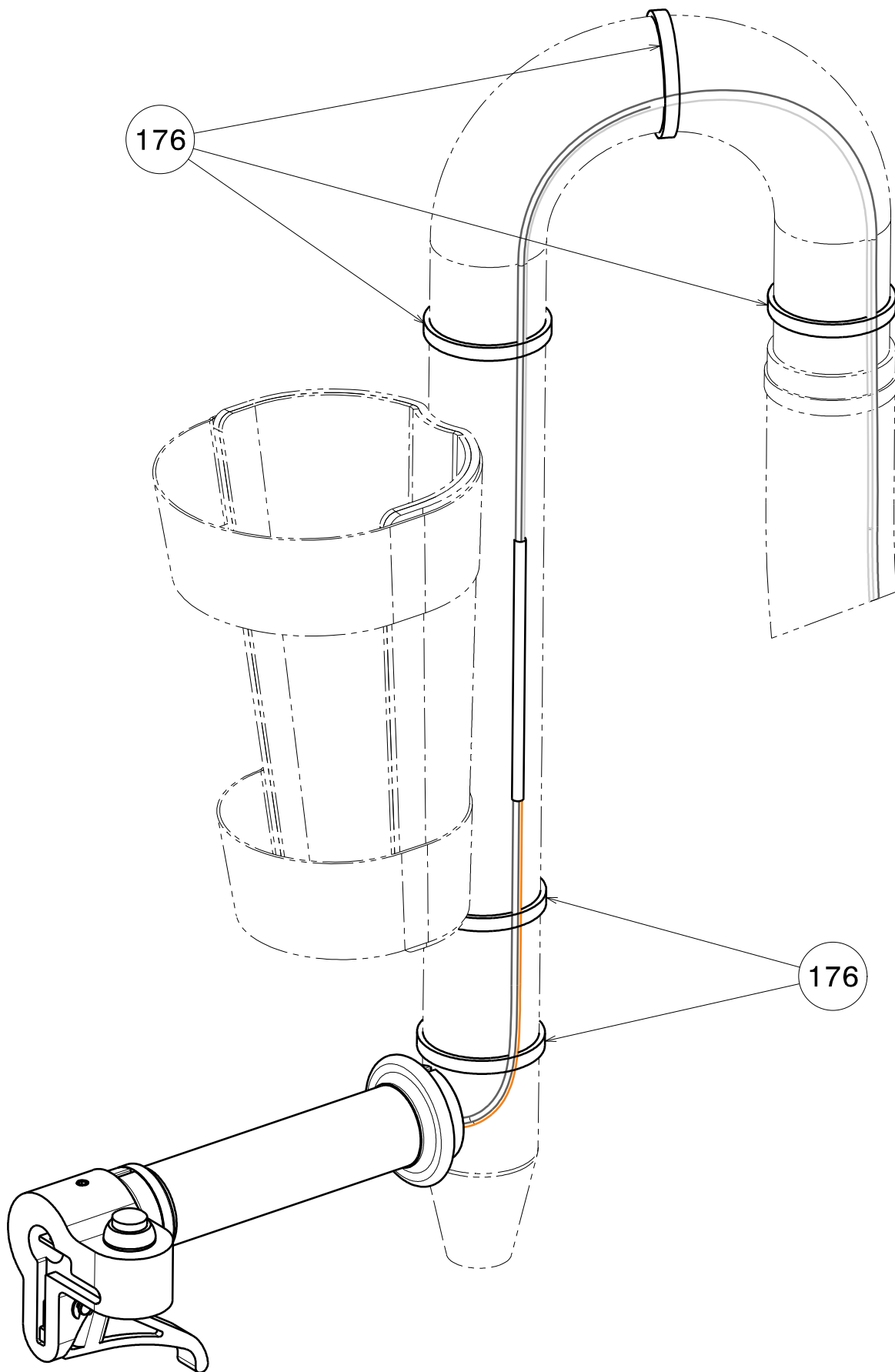

INSTRUCTIONS:

PUT THE CABLE ALONG THE STABILIZER ITEM.A06 WITH A CLAMP ITEM.176

PHASE 6-21: SETTING THE PROTECTION

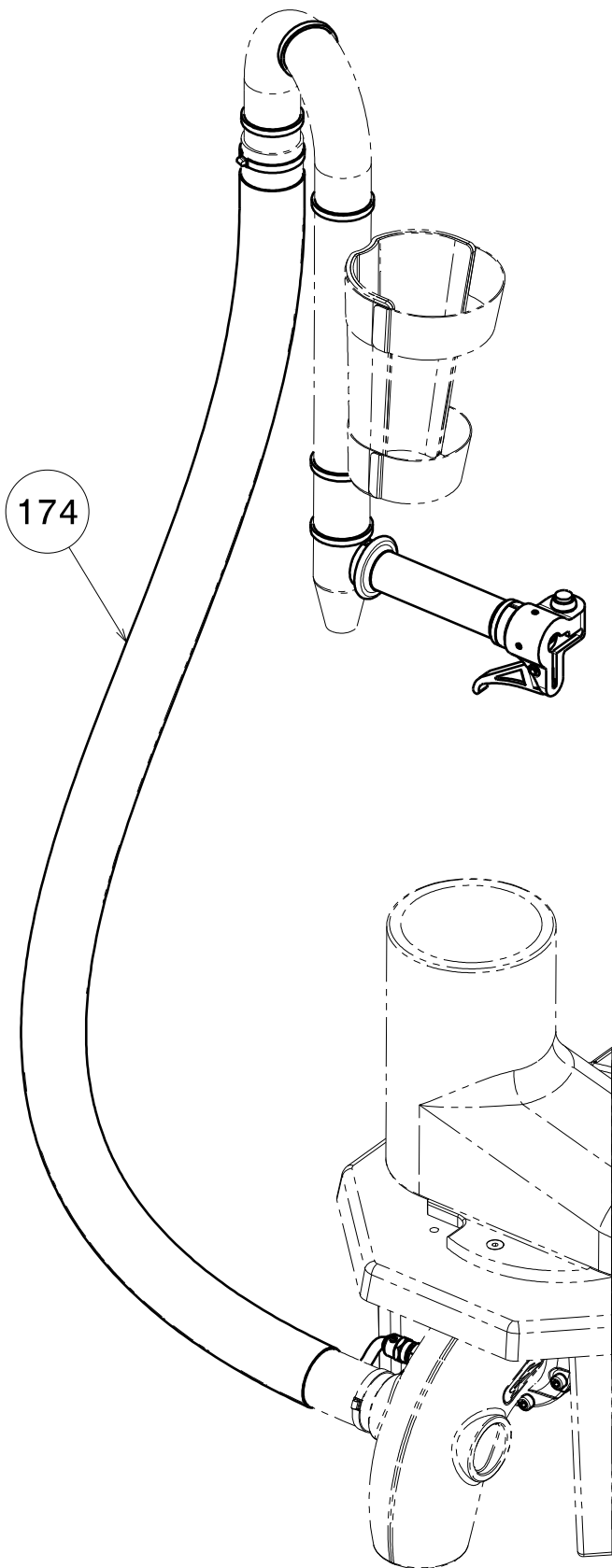

174



!

INSTRUCTION:
RETRACT THE PROTECTION SOCK WITH A HOT AIR BLOWER
WARNING: AN EXCESSIVE HEAT CAN TEAR THE SOCK

PHASE 7-1: CONNECTION BEFORE USING

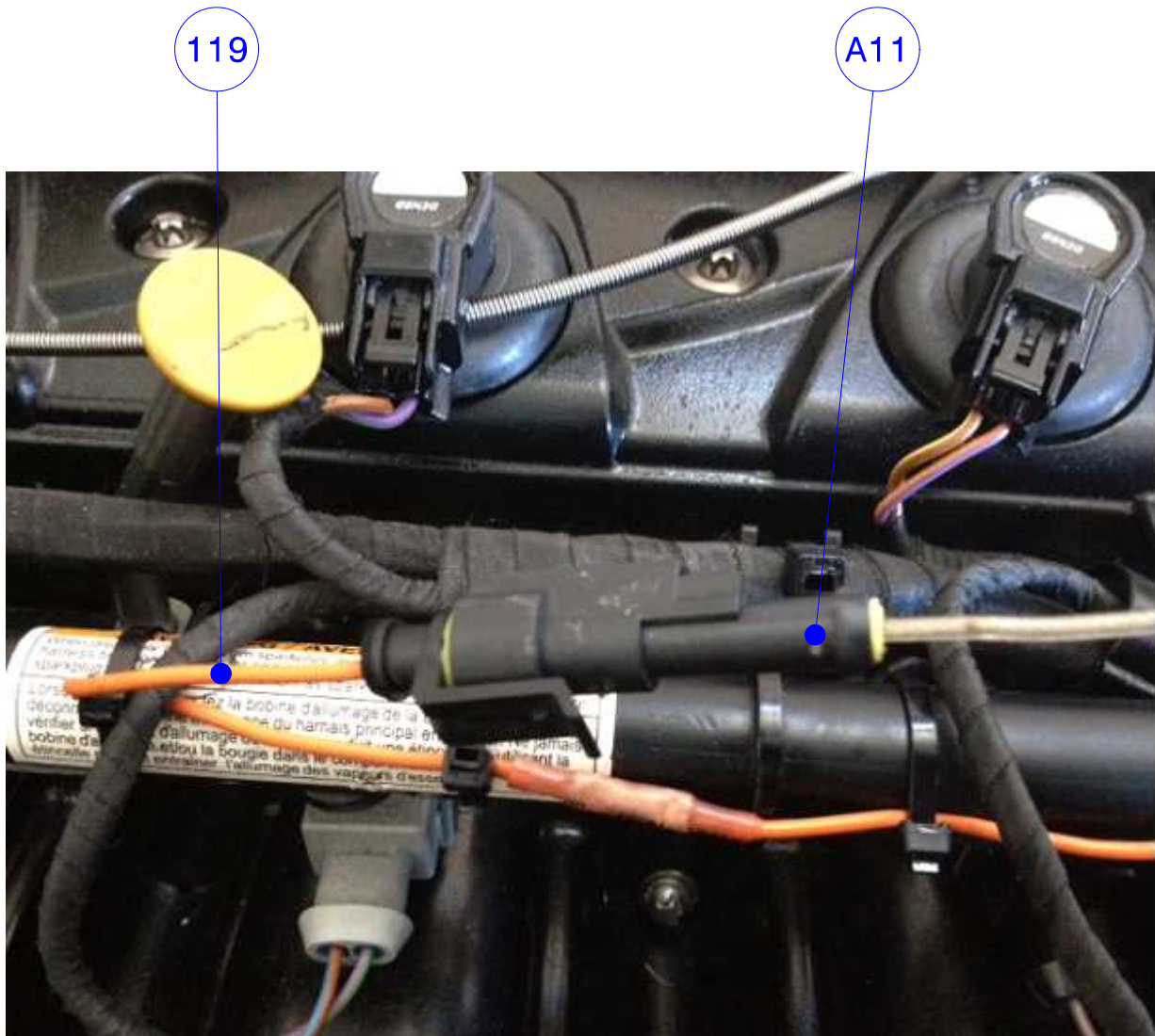

INSTRUCTIONS:

1. CONNECT THE ELBOW TO THE PWC
2. CONNECT THE STAINLESS STEEL CABLE REP. A11 TO THE ORANGE WIRE REP. 119 OF THE FLYBOARD'S CASE

PHASE 8-1: CALIBRAGE DE LA GACHETTE

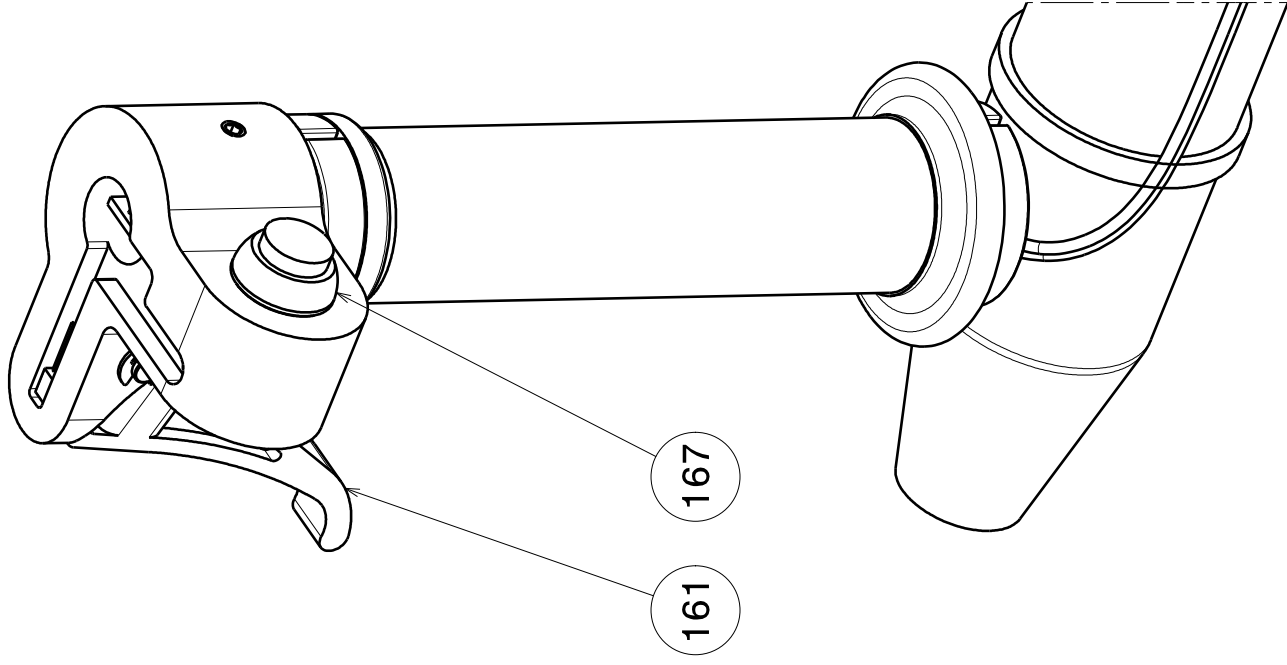
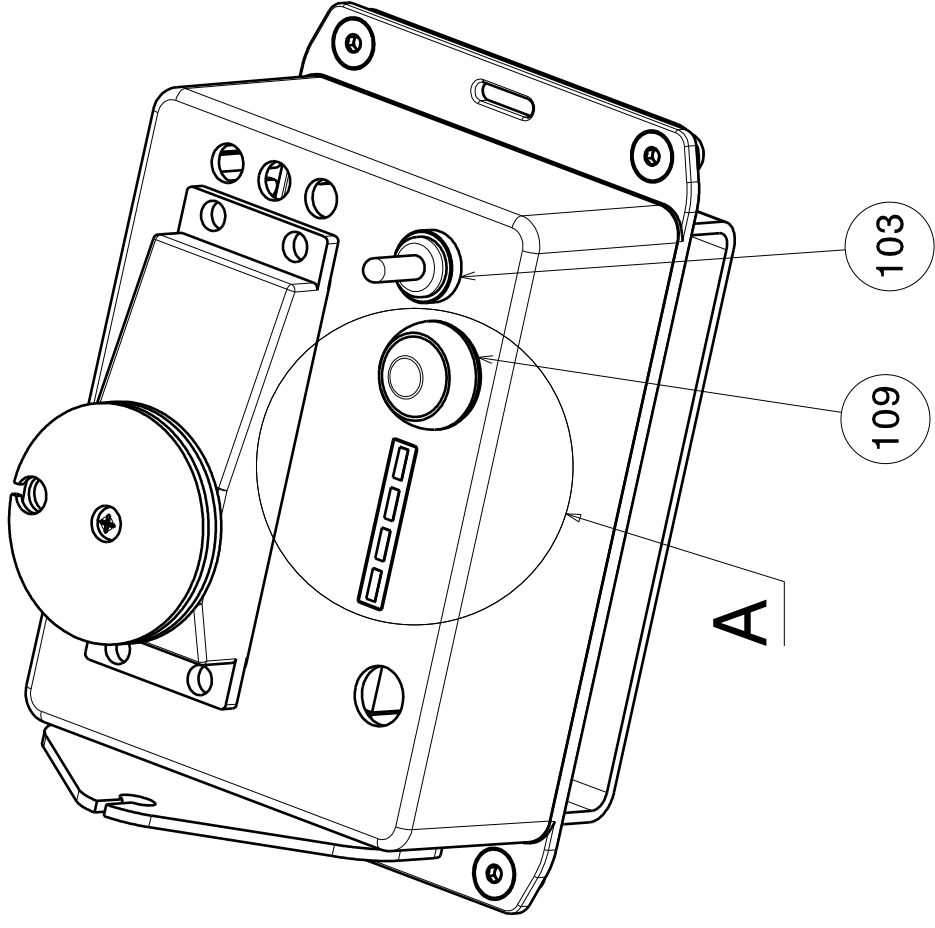

- INSTRUCTIONS:**
 COVER MAY BE REQUIRED TO BE RECALIBRATED (SEE "CALIBRATION TO DO")
1. MAINTAIN THE BUTTONS ITEM.167 AND 109 PUSHED
 2. SWITCH ON THE REP 103 LEVER (LED'S POSITION CHANGE, SEE "CALIBRATION IN PROGRESS")
 3. WHILE MAINTAINING BUTTONS ITEM.167 AND 109, PRESS AND RELEASE 3 TIMES THE TRIGGER THROTTLE TO CALIBRATE THE 0% OPENING POSITION AND 100% OPENING POSITION
 4. RELEASE THE TWO BUTTONS

CALIBRATION TO DO

DETAIL A

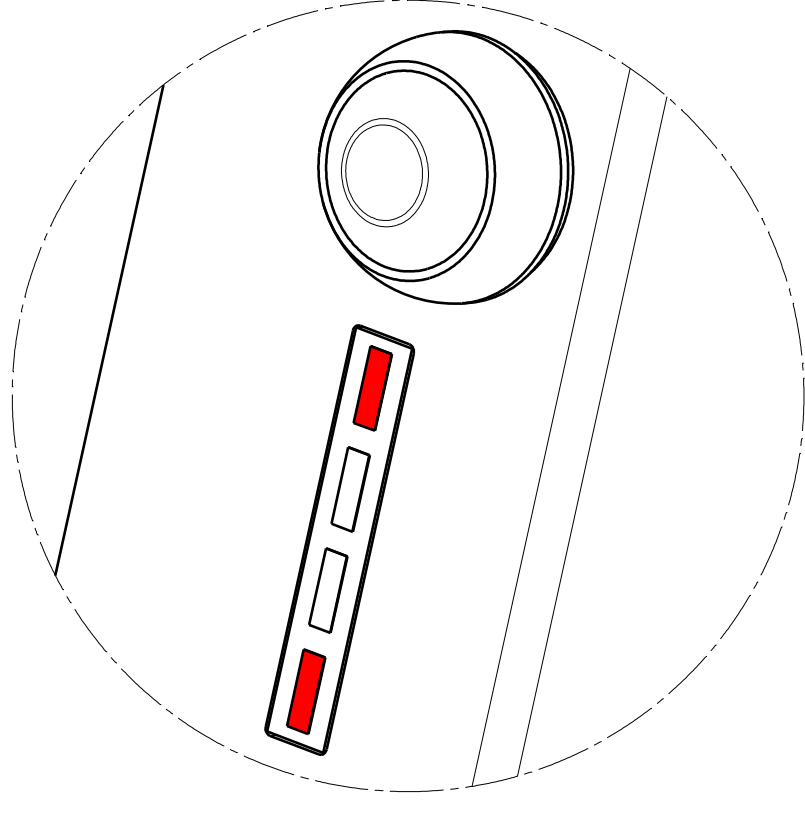

CALIBRATION IN PROGRESS

DETAIL A

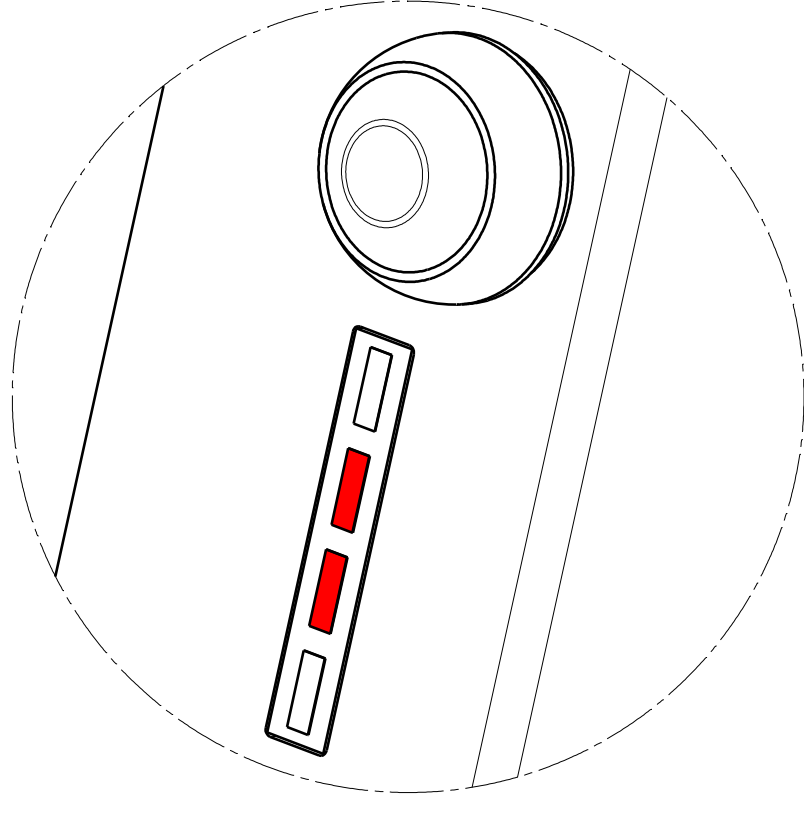

PHASE 8-2: PROGRAMMING FLYBOARD'S CASE

SEAD00 POSITION

DETAIL A

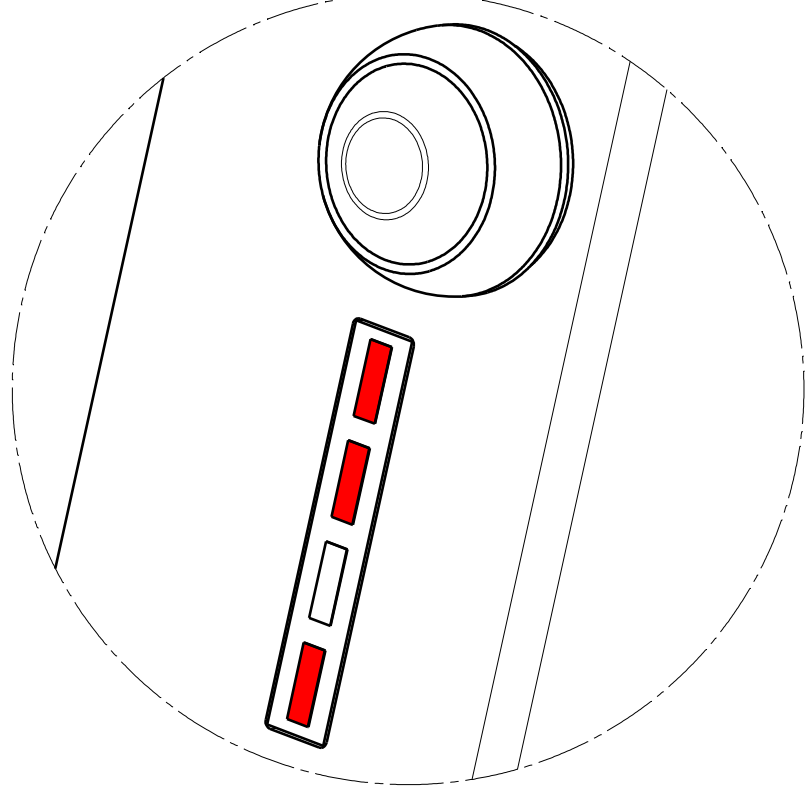

YAMAHA / KAWASAKI POSITION

DETAIL A

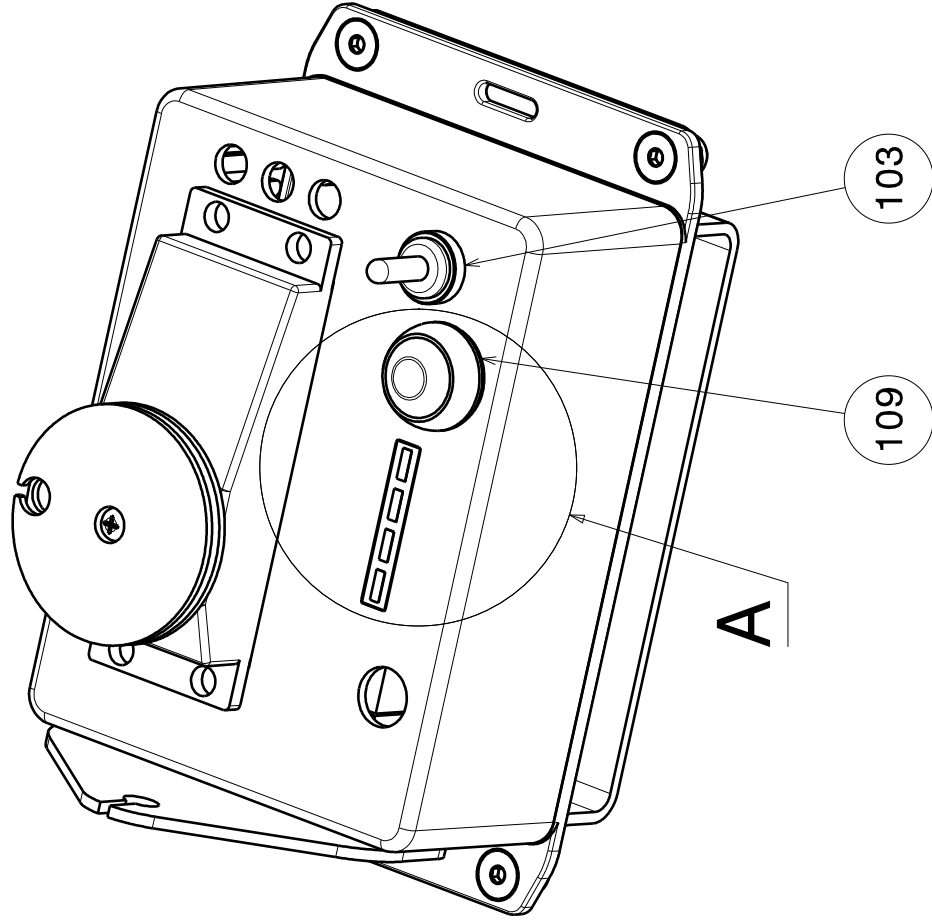
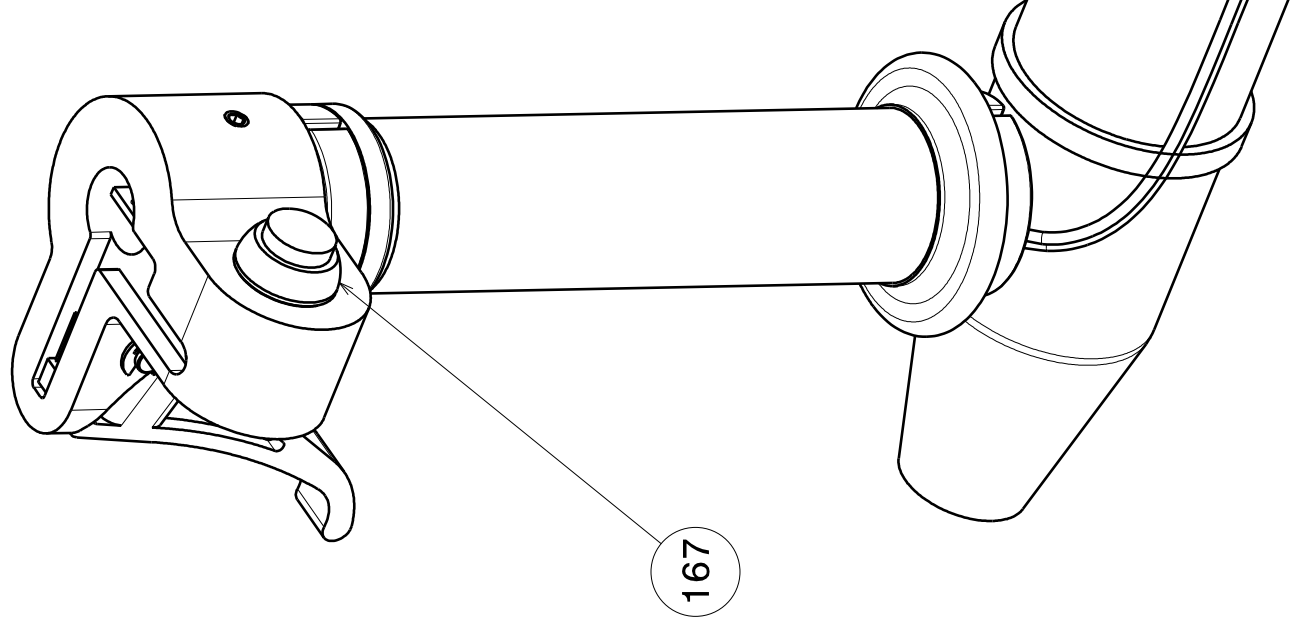
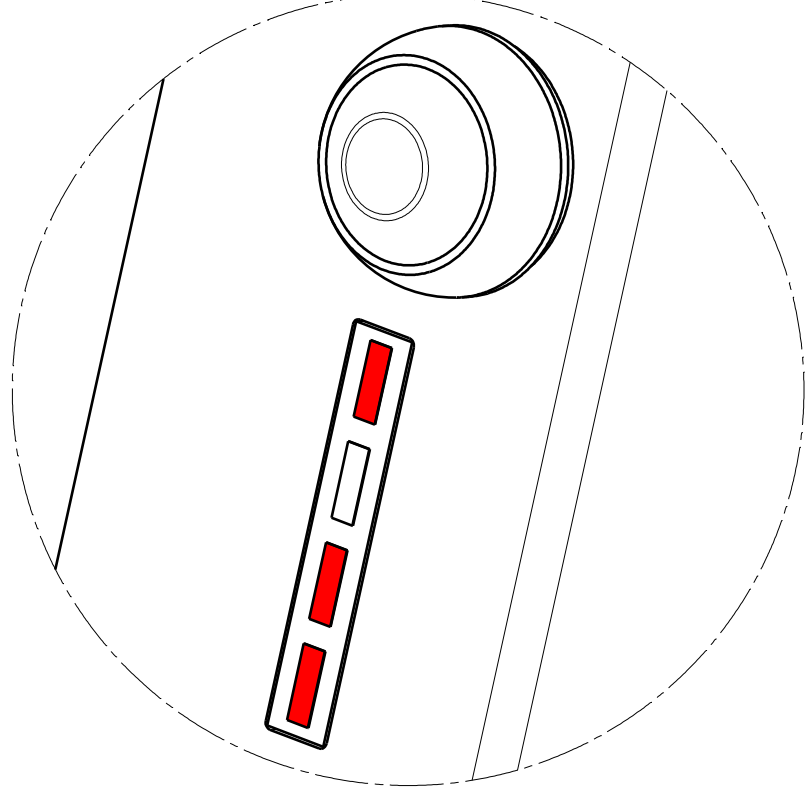

INSTRUCTIONS:

1. HOLD THE BUTTON ITEM.169
2. TURN ON THE CASE WITH THE LEVER ITEM.107
3. CHANGE MODE PRESSING SUCCESSIVELY THE BUTTON ITEM.167

PHASE 8-3: CALIBRATION OF THE FLYBOARD'S POWER

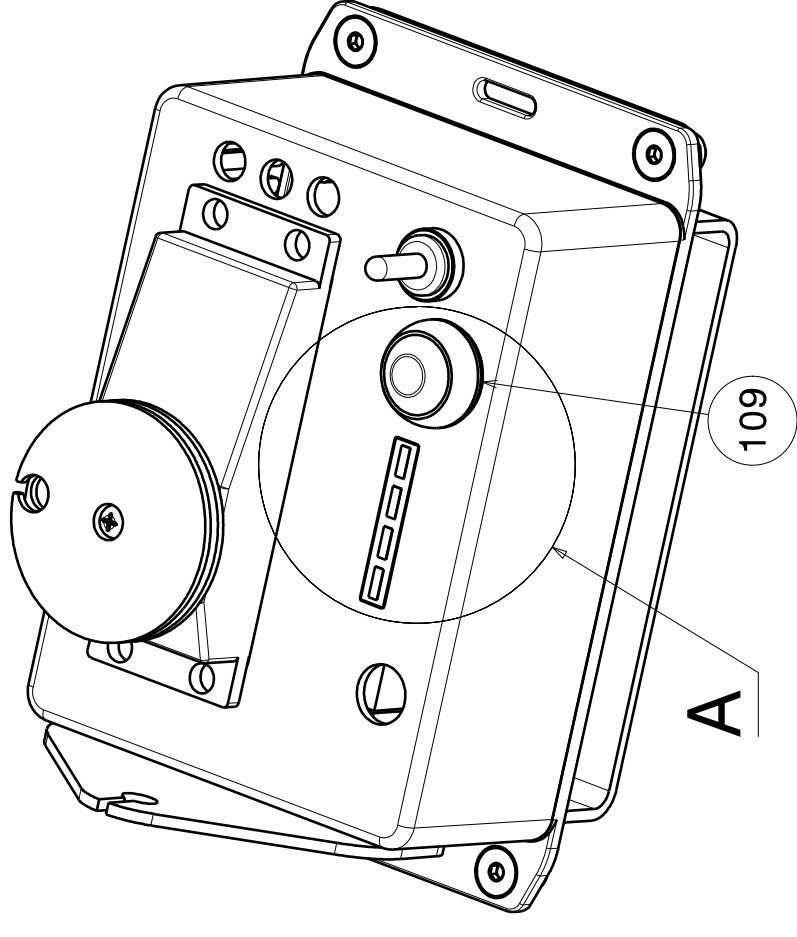

INSTRUCTIONS:
 1. CHOOSE THE MODE ACCORDING TO YOUR LEVEL PUSHING THE BUTTON ITEM.109
 (CF THE FLYBOARD'S MANUAL)
 2. THE CASE KEEPS IN MEMORY THE LAST POSITION OF THE LAST USING

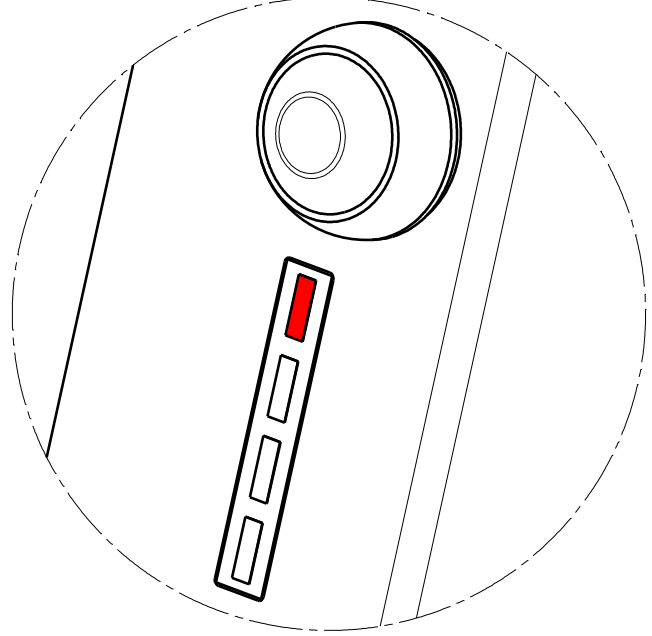
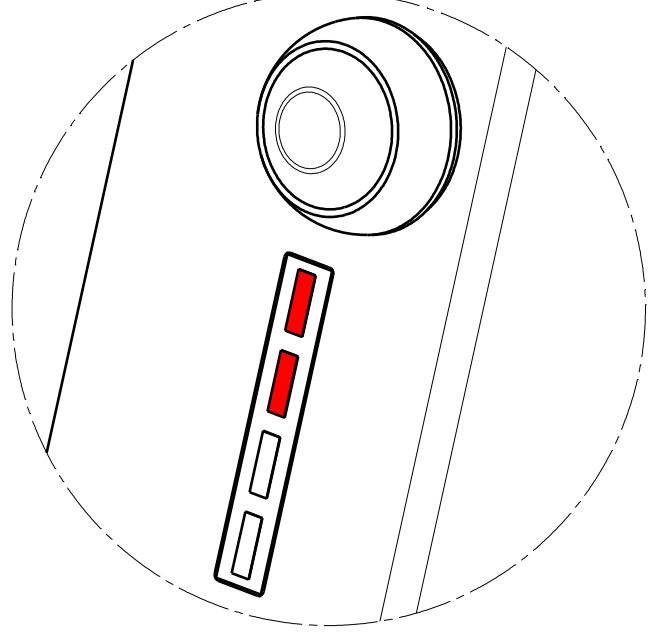
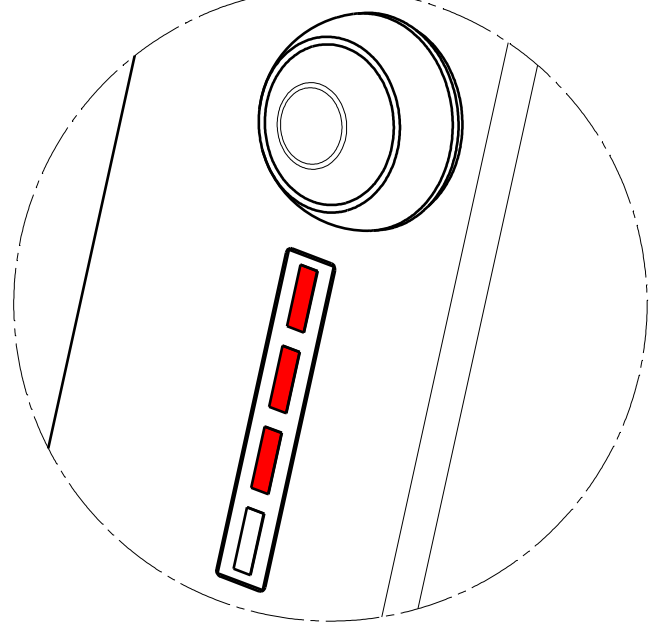
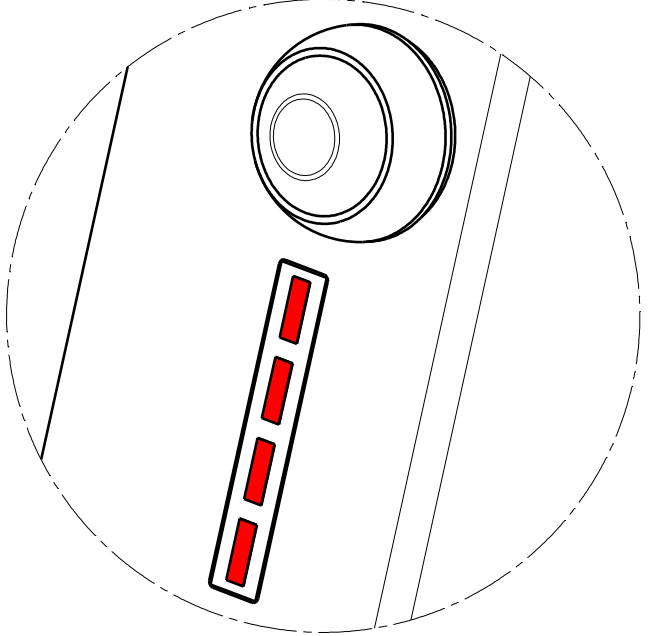
<p>1 LED LIT: MAXIMUM 4500 RPM</p> <p>DETAIL A</p>	<p>2 LED LIT: MAXIMUM 5500 RPM</p> <p>DETAIL A</p>	<p>3 LED LIT: MAXIMUM 7000 RPM</p> <p>DETAIL A</p>	<p>4 LED LIT: PWC MAXIMUM POWER</p> <p>DETAIL A</p>
			

USING INSTRUCTIONS

TURN ON THE CASE

THE CIRCUIT BREAKER MUST BE CONNECTED TO USE THE PWC

WARNING !

FOR THE SEADOO THE CIRCUIT BREAKER MUST BE PRESSED FULLY IN THE DESS IF IT'S NOT DONE CORRECTLY THE SEADOO WON'T RESTART WHEN USING THE FLYBOARD, ESPECIALLY IN "DEAD MAN SAFETY FUNCTION" (EXPLAINED BELOW) THE CHARACTERISTIC NOISE WILL BE A LONG BEEP INSTEAD OF 2 SHORT AND CLOSE BEEPS

BE SURE THAT THE PWC WORKS CORRECTLY BEFORE USING IT

TEST :

- START
 - DO NOT USE THE TRIGGER FOR 3 SECONDS, THE ENGINE WILL SHUT OFF AUTOMATICALLY
 - PULL THE TRIGGER, THE SEADOO MUST ISSUE TWO SHORT AND CLOSE BEEPS, THIS MEANS THAT THE CIRCUIT BREAKER IS PUSHED TO START, PRESS THE RED BUTTON OF THE FLYBOARD TILL THE PWC STARTS (YAMAHA AND KAWASAKI WILL START HALF A SECOND AFTER PRESSING THE RED BUTTON) TO STOP THE PWC JUST GIVE A PULSE ON THE SAME RED BUTTON
- THE FLYBOARD HAS A "DEAD MAN SAFETY FUNCTION":
IF THE TRIGGER IS NOT USED DURING SEVERAL SECONDS, THE ENGINE OF THE PWC WILL STOP AUTOMATICALLY
TO START AGAIN JUST PULL THE TRIGGER AND PUSH THE RED BUTTON OR PUSH THE RED BUTTON TWICE
IF THE CABLE IS CUT OR DISCONNECTED WHEN USING, THE POWER WILL BE REDUCED PROGRESSIVELY UNTIL THE ENGINE WILL BE TURNED OFF
BEFORE START AGAIN BE SURE THAT THE CONNECTION CABLES ARE UNDAMAGED
THE CASE MUST BE TURNED OFF TO USE THE PWC WITHOUT THE FLYBOARD (NO LED ON)

MAINTENANCE INSTRUCTIONS

- RINSE WITH CLEAR WATER ALL THE PARTS OF THE ELECTRONIC KIT AFTER USE IN SALTED WATER
- BEFORE EACH STORAGE USE A SPRAY CORROSION RESISTANT FOR THE STAINLESS STEEL BEARING AND THE TRIGGER CONTROL
- DO NOT USE ANTI CORROSION SPRAY ON THE HOOD SEAL OF THE SWITCH, THIS CAN DAMAGE THE RUBBER
- BE SURE THAT THE BEARING IS FREE BEFORE EACH USE (IF THE BEARING IS BLOCKED THIS CAN CAUSE IRREVERSIBLE DAMAGE TO THE ELECTRICAL CONNECTIONS CABLE)
- IF THE CABLE IS DAMAGED THE ELECTROLYSIS DESTROY THE CABLE WITHIN 2 TO 3 HOURS FOLLOWING THE INCIDENT, IN WHICH CASE YOU MUST RETURN THE ENTIRE ASSEMBLY (CABLE + SHEATH) TO THE HEAD OFFICE (ZAPATA RACING)
- AS WITH ALL OTHER PARTS OF FLYBOARD ® AND AS EXPLAINED IN THE MANUAL OF THE FLYBOARD ®, DO NOT START THE PWC IN AN INSUFFICIENT DEPTH IN THE SAND SO AS NOT TO BLOCK THE REAR BEARING.